

10" Deluxe Bandsaw



Operator's Manual

Record the serial number and date of purchase in your manual for future reference.

The serial number can be found on the specification label on the rear of your machine.

Serial Number: _____ Date of purchase: _____

For technical support or parts questions, email techsupport@rikontools.com or call toll free at (877)884-5167

TABLE OF CONTENTS

| | |
|--|---------|
| Specifications..... | 2 |
| Safety Instructions | 3 - 6 |
| Getting To Know Your Machine | 7 |
| Contents of Package | 8 - 9 |
| Installation | 9 |
| Assembly | 10 - 12 |
| Adjustments..... | 12 - 19 |
| Operation | 20 |
| Maintenance | 20 |
| Wiring Diagram | 21 |
| Troubleshooting | 21 - 23 |
| Parts Diagrams & Parts Lists | 24 - 27 |
| Notes | 28 |
| Accessories | 29 |
| 'How To' Guide for all Band Saw Blades | 30 |
| Warranty | 31 |

SPECIFICATIONS

| | |
|--------------------------------------|--|
| Motor | 1/2 HP, TEFC |
| Motor Speed (no load)..... | 1,720 RPM |
| Volts | 110 V |
| Amps, Hertz, Phase | 5.5 A, 60 Hz, 1Ph |
| Blade Length | 70-1/2" (1,791 mm) |
| Blade Width | 1/8" *- 1/2" (3.18 * - 12.7 mm) |
| Blade Speed | 1,515 / 3,280 ft/min (462 / 1,000 m/min) |
| Table Size (W x D) | 13-3/4" x 12-1/2" (350 x 320 mm) |
| Table Tilt | Left -5°, Right 45° |
| Miter Gauge Slots (1) | 5/8" x 1/4" (16 x 6.5 mm) |
| Maximum Cutting Width (throat) | 9-5/8" (244.5 mm) |
| Maximum Cutting Depth (height) | 5" (127 mm) |
| Table Height to Base | 14-1/2" (368 mm) |
| Fence Height | 2-3/8" (60 mm) |
| Fence Length | 12-1/4" (310 mm) |
| Dust Ports (1) | 2-1/2" O.D. / 2-1/4" I.D (64 / 57 mm) |
| Base Size (WxD) | 15-7/8" x 9-3/8" (403 x 238 mm) |
| Overall Height | 34-1/4" (870 mm) |
| Overall Width x Depth..... | 21" x 16-1/4" (534 x 413 mm) |
| Net Weight | 77.5 lbs. (35.14 kg) |

* 1/8" (3.18mm) bandsaw blades should be 0.018" to 0.020" gauge to reduce tracking issues common with this width.

NOTE: The specifications, photographs, drawings and information in this manual represent the current model when the manual was prepared. Changes and improvements may be made at any time, with no obligation on the part of Rikon Power Tools, Inc. to modify previously delivered units. Reasonable care has been taken to ensure that the information in this manual is correct, to provide you with the guidelines for the proper safety, assembly and operation of this machine.

SAFETY INSTRUCTIONS

IMPORTANT! Safety is the single most important consideration in the operation of this equipment. **The following instructions must be followed at all times.** Failure to follow all instructions listed below may result in electric shock, fire, and/or serious personal injury.

There are certain applications for which this tool was designed. We strongly recommend that this tool not be modified and/or used for any other application other than that for which it was designed. If you have any questions about its application, do not use the tool until you have contacted us and we have advised you.

SAFETY SYMBOLS



SAFETY ALERT SYMBOL: Indicates DANGER, WARNING, or CAUTION. This symbol may be used in conjunction with other symbols or pictographs.



Indicates an imminently hazardous situation, which, if not avoided, could result in death or serious injury.



Indicates a potentially hazardous situation, which, if not avoided, could result in death or serious injury.



Indicates a potentially hazardous situation, which, if not avoided, could result in minor or moderate injury.

NOTICE: Shown without Safety Alert Symbol indicates a situation that may result in property damage.

GENERAL SAFETY

KNOW YOUR POWER TOOL. Read the owner's manual carefully. Learn the tool's applications, work capabilities, and its specific potential hazards.

BEFORE USING YOUR MACHINE

To avoid serious injury and damage to the tool, read and follow all of the Safety and Operating Instructions before operating the machine.

1. California Proposition 65 Warning: Some dust created by power sanding, sawing, grinding, drilling and other construction activities contains chemicals known to the State of California to cause cancer, birth defects, or other reproductive harm. Some examples of these chemicals are:

- Lead from lead-based paints.
- Crystalline silica from bricks, cement, and other
- Masonry products.
- Arsenic and chromium from chemically treated lumber.

Your risk from exposure to these chemicals varies, depending on how often you do this type of work. To reduce your exposure, work in a well ventilated area and work with approved safety equipment, such as dust masks that are specially designed to filter out microscopic particles.

2. READ the entire Owner's Manual. **LEARN** how to use the tool for its intended applications.

3. GROUND ALL TOOLS. If the tool is supplied with a 3 prong plug, it must be plugged into a 3-contact electrical receptacle. The 3rd prong is used to ground the tool and provide protection against accidental electric shock. **DO NOT** remove the 3rd prong. See Grounding Instructions on the following pages.

4. AVOID A DANGEROUS WORKING ENVIRONMENT. DO NOT use electrical tools in a damp environment or expose them to rain.

5. DO NOT use electrical tools in the presence of flammable liquids or gasses.

6. ALWAYS keep the work area clean, well lit, and organized. **DO NOT** work in an environment with floor surfaces that are slippery from debris, grease, and wax.

7. KEEP VISITORS AND CHILDREN AWAY. DO NOT permit people to be in the immediate work area, especially when the electrical tool is operating.

8. DO NOT FORCE THE TOOL to perform an operation for which it was not designed. It will do a safer and higher quality job by only performing operations for which the tool was intended.

9. WEAR PROPER CLOTHING. DO NOT wear loose clothing, gloves, neckties, or jewelry. These items can get caught in the machine during operations and pull the operator into the moving parts. The user must wear a protective cover on their hair, if the hair is long, to prevent it from contacting any moving parts.

10. CHILDPROOF THE WORKSHOP AREA by removing switch keys, unplugging tools from the electrical receptacles, and using padlocks.

11. ALWAYS UNPLUG THE TOOL FROM THE ELECTRICAL RECEPTACLE when making adjustments, changing parts or performing any maintenance.

SAFETY INSTRUCTIONS

12. KEEP PROTECTIVE GUARDS IN PLACE AND IN WORKING ORDER.

13. AVOID ACCIDENTAL STARTING. Make sure that the power switch is in the “OFF” position before plugging in the power cord to the electrical receptacle.

14. REMOVE ALL MAINTENANCE TOOLS from the immediate area prior to turning “ON” the machine.

15. USE ONLY RECOMMENDED ACCESSORIES. Use of incorrect or improper accessories could cause serious injury to the operator and cause damage to the tool. If in doubt, check the instruction manual that comes with that particular accessory.

16. NEVER LEAVE A RUNNING TOOL UNATTENDED. Turn the power switch to the “OFF” position. **DO NOT** leave the tool until it has come to a complete stop.

17. DO NOT STAND ON A TOOL. Serious injury could result if the tool tips over, or you accidentally contact the tool.

18. DO NOT store anything above or near the tool where anyone might try to stand on the tool to reach it.

19. MAINTAIN YOUR BALANCE. DO NOT extend yourself over the tool. Wear oil resistant rubber soled shoes. Keep floor clear of debris, grease, and wax.

20. MAINTAIN TOOLS WITH CARE. Always keep tools clean and in good working order. Keep all blades and tool bits sharp, dress grinding wheels and change other abrasive accessories when worn.

21. EACH AND EVERY TIME, CHECK FOR DAMAGED PARTS PRIOR TO USING THE TOOL. Carefully check all guards to see that they operate properly, are not damaged, and perform their intended functions. Check for alignment, binding or breaking of moving parts. A guard or other part that is damaged should be immediately repaired or replaced.

22. DO NOT OPERATE TOOL WHILE TIRED, OR UNDER THE INFLUENCE OF DRUGS, MEDICATION OR ALCOHOL.

23. SECURE ALL WORK. Use clamps or jigs to secure the work piece. This is safer than attempting to hold the work piece with your hands.

24. STAY ALERT, WATCH WHAT YOU ARE DOING, AND USE COMMON SENSE WHEN OPERATING A POWER TOOL.
A moment of inattention while operating power tools may result in serious personal injury.

25. ALWAYS WEAR A DUST MASK TO PREVENT INHALING DANGEROUS DUST OR AIRBORNE PARTICLES, including wood dust, crystalline silica dust and asbestos dust. Direct particles away from face and body. Always operate tool in well ventilated area and provide for proper dust removal. Use dust collection system wherever possible. Exposure to the dust may cause serious and permanent respiratory or other injury, including silicosis (a serious lung disease), cancer, and death. Avoid breathing the dust, and avoid prolonged contact with dust. Allowing dust to get into your mouth or eyes, or lay on your skin may promote absorption of harmful material. Always use properly fitting NIOSH/OSHA approved respiratory protection appropriate for the dust exposure, and wash exposed areas with soap and water.

26. USE A PROPER EXTENSION CORD IN GOOD CONDITION. When using an extension cord, be sure to use one heavy enough to carry the current your product will draw. The table on the following page shows the correct size to use depending on cord length and nameplate amperage rating. If in doubt, use the next heavier gauge. The smaller the gauge number, the larger diameter of the extension cord. If in doubt of the proper size of an extension cord, use a shorter and thicker cord. An undersized cord will cause a drop in line voltage resulting in a loss of power and overheating.
USE ONLY A 3-WIRE EXTENSION CORD THAT HAS A 3-PRONG GROUNDING PLUG AND A 3-POLE RECEPTACLE THAT ACCEPTS THE TOOL’S PLUG.

27. ADDITIONAL INFORMATION regarding the safe and proper operation of this product is available from:

- Power Tool Institute
1300 Summer Avenue
Cleveland, OH 44115-2851
www.powertoolinstitute.org
- National Safety Council
1121 Spring Lake Drive
Itasca, IL 60143-3201
www.nsc.org
- American National Standards Institute
25 West 43rd Street, 4th Floor
New York, NY 10036
www.ansi.org
- ANSI 01.1 Safety Requirements for Woodworking Machines and the U.S. Department of Labor regulations
www.osha.gov

28. SAVE THESE INSTRUCTIONS. Refer to them frequently and use them to instruct others.

SAFETY INSTRUCTIONS

ELECTRICAL SAFETY

⚠ WARNING: THIS 110V TOOL MUST BE GROUND-ED WHILE IN USE TO PROTECT THE OPERATOR FROM ELECTRIC SHOCK.

IN THE EVENT OF A MALFUNCTION OR BREAKDOWN, grounding provides the path of least resistance for electric current and reduces the risk of electric shock. This tool is equipped with an electric cord that has an equipment grounding conductor and requires a grounding plug (not included). The plug **MUST** be plugged into a matching electrical receptacle that is properly installed and grounded in accordance with **ALL** local codes and ordinances.

DO NOT MODIFY ANY PLUG. If it will not fit the electrical receptacle, have the proper electrical receptacle installed by a qualified electrician.

IMPROPER ELECTRICAL CONNECTION of the equipment grounding conductor can result in risk of electric shock. The conductor with the green insulation (with or without yellow stripes) is the equipment grounding conductor. **DO NOT** connect the equipment grounding conductor to a live terminal if repair or replacement of the electric cord or plug is necessary.

CHECK with a qualified electrician or service personnel if you do not completely understand the grounding instructions, or if you are not sure the tool is properly grounded when installing or replacing a plug.

USE ONLY A 3-WIRE EXTENSION CORD THAT HAS THE PROPER TYPE OF A 3-PRONG GROUNDING PLUG THAT MATCHES THE MACHINE'S 3-PRONG PLUG AND ALSO THE 3-POLE RECEPTACLE THAT ACCEPTS THE TOOL'S PLUG. *

REPLACE A DAMAGED OR WORN CORD IMMEDIATELY.

This tool is intended for use on a circuit that has an electrical receptacle as shown in **FIGURE A**. It shows a 3-wire electrical plug and electrical receptacle that has a grounding conductor. If a properly grounded electrical receptacle is not available, an adapter as shown in **FIGURE B** can be used to temporarily connect this plug to a 2-contact ungrounded receptacle. The adapter has a rigid lug extending from it that **MUST** be connected to a permanent earth ground, such as a properly grounded receptacle box. **THIS ADAPTER IS PROHIBITED IN CANADA.**

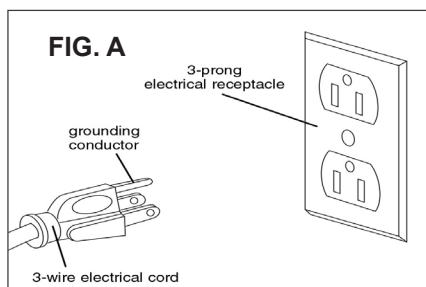

EXTENSION CORDS

⚠ WARNING: THE USE OF AN EXTENSION CORD WITH THIS MACHINE IS NOT RECOMMENDED. For best power and safety, plug the machine directly into a dedicated, grounded electrical outlet that is within the supplied cord length of the machine.

If an extension cord needs to be used, it should only be for a limited operation of the machine. The extension cord should be as short as possible in length, and have a minimum gauge size of 14AWG.

⚠ WARNING: Check extension cords before each use. If damaged replace immediately. Never use a tool with a damaged cord, since touching the damaged area could cause electrical shock, resulting in serious injury.

Use a proper extension cord. Only use cords listed by Underwriters Laboratories (UL). Other extension cords can cause a drop in line voltage, resulting in a loss of power and overheating of tool. When operating a power tool outdoors, use an outdoor extension cord marked "W-A" or "W". These cords are rated for outdoor use and reduce the risk of electric shock.

MINIMUM RECOMMENDED GAUGE FOR EXTENSION CORDS (AWG)

| 120 VOLT OPERATION ONLY | | | | |
|-------------------------|----------|----------|-----------|-----------|
| | 25' LONG | 50' LONG | 100' LONG | 150' LONG |
| 0 to 6 Amps | 18 AWG | 16 AWG | 16 AWG | 14 AWG |
| 6 to 10 Amps | 18 AWG | 16 AWG | 14 AWG | 12 AWG |
| 10 to 12 Amps | 16 AWG | 16 AWG | 14 AWG | 12 AWG |

⚠ WARNING: Keep the extension cord clear of the working area. Position the cord so that it will not get caught on lumber, tools or other obstructions while you are working with your power tool.

* Canadian electrical codes require extension cords to be certified SJT type or better.

** The use of an adapter in Canada is not acceptable.

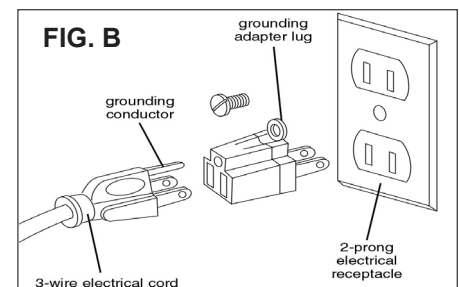

SAFETY INSTRUCTIONS

SPECIFIC SAFETY INSTRUCTIONS FOR BAND SAWS

This machine is intended for the cutting of natural, solid woods, composite materials, plastics and non-ferrus metals. The permissible workpiece dimensions must be observed (see Technical Specification). Any other use not as specified, including modification of the machine or use of parts not tested and approved by the equipment manufacturer, can cause unforeseen damage and invalidate the warranty.

ATTENTION: Use of this band saw still presents risks that cannot be eliminated by the manufacturer. Therefore, the user must be aware that wood working machines are dangerous if not used with care and all safety precautions are adhered to.

1. Do not operate this machine until you have read all of the following instructions.
2. If you are not familiar with the operation of the machine, obtain assistance from a qualified person.
3. Always wear approved, safety protective eye wear and hearing protection when operating this machine.
4. Always wear a dust mask and use adequate dust collection and proper ventilation.
5. Adjust the upper guides about 1/8" to 1/4" above the material being cut.
6. Check for proper blade size and type for the thickness and type of material being cut.
7. Make sure that the blade tension and blade tracking are properly adjusted.
8. Always keep hands and fingers away from the blade.
9. Make "relief" cuts before cutting curves to eliminate blade binding.
10. Always hold material firmly, resting flat on the table and feed it into the blade at a moderate speed.
11. Never attempt to saw stock that does not have a flat surface, unless a suitable support is used.
12. When cutting small work pieces, always use a push stick, holding jig or other device to keep your hands safely away from the blade. Use 'Zero Clearance Inserts' to prevent small pieces from becoming jammed in the table insert or lower blade guides.
13. Always allow the bandsaw blade to stop before removing scrap pieces from the table.
14. Do not remove jammed pieces from the saw until the machine and blade has stopped. Unplug the bandsaw from the power source, and then remove the jammed work piece.
15. Always turn off the machine if the material is to be backed out of an uncompleted cut.
16. Use extra supports (roller stands, saw horses, tables etc.) for any work pieces large enough to tip when not held down to the table top surface.
17. Always turn off and unplug the machine when changing blades or servicing the machine.
18. Release blade tension when the saw will not be used for a long period of time.
19. Remove material or debris from the work area. Keep work area neat and clean.

SAVE THESE INSTRUCTIONS.

Refer to them often.

California Proposition 65 Warning: Drilling, sawing, sanding or machining wood products can expose you to wood dust, a substance known to the State of California to cause cancer. Avoid inhaling wood dust or use a dust mask or other safeguards for personal protection.

For more information go to www.P65Warnings.ca.gov/wood

This owner's manual is not a teaching aid. Use of this owner's manual is intended to show assembly, adjustments, and general use.

GETTING TO KNOW YOUR MACHINE

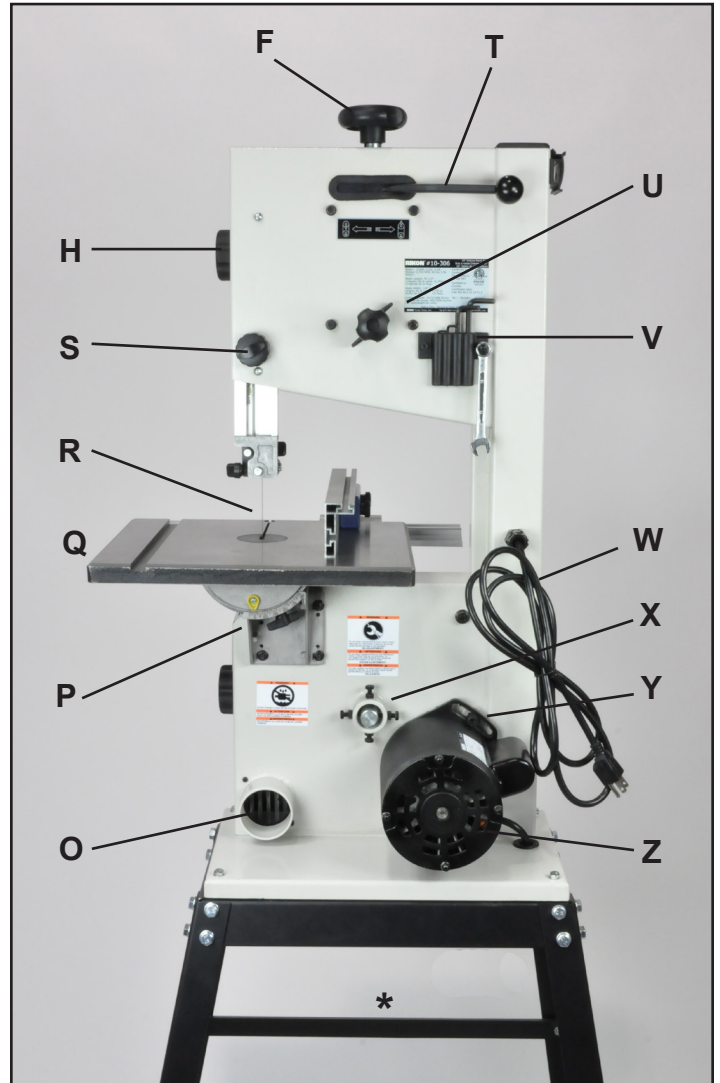
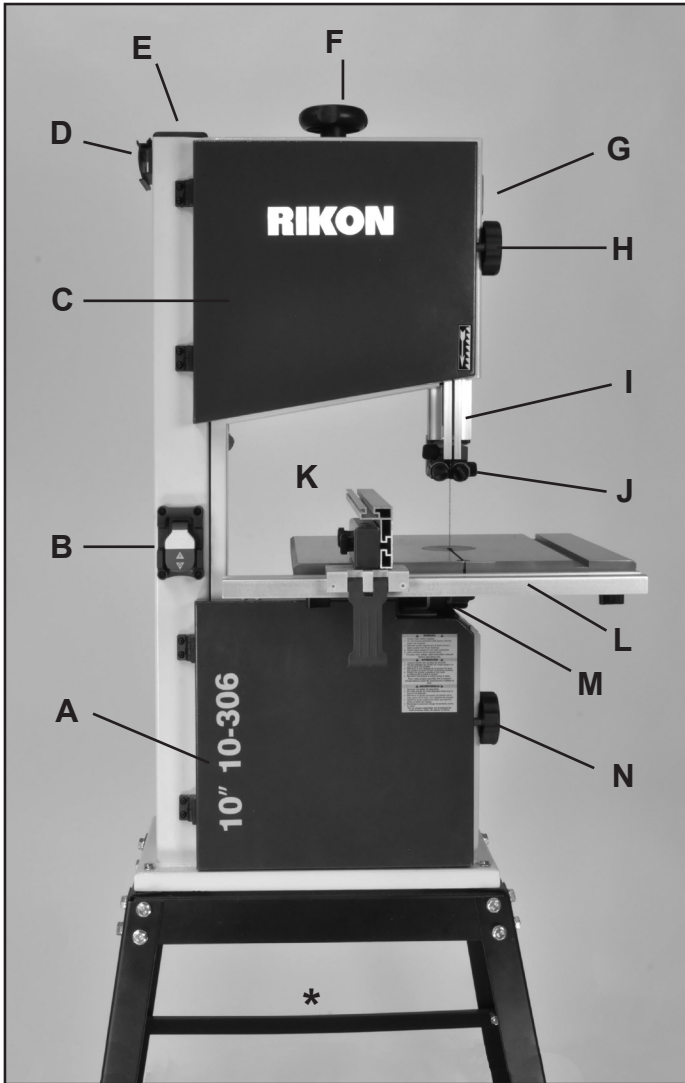

* Shown on #13-913 Stand (available separately)

- | | |
|----------------------------------|---|
| A. Lower Door | O. Dust Port |
| B. ON / OFF Switch | P. Trunnion with Table Locking Handle and Angle Scale |
| C. Upper Door | Q. Table with Miter Gauge Slot |
| D. Holder for Rip Fence Assembly | R. Bandsaw Blade & Table Insert |
| E. Column Post Cap | S. Guide Post Adjustment & Locking Knob |
| F. Blade Tension Handle | T. Quick Release Blade Tension Lever |
| G. Blade Tracking Window | U. Blade Tracking Handle & Locking Nut |
| H. Upper Door Locking Knob | V. Tool Holder |
| I. Blade Guard | W. Power Cord |
| J. Upper Blade Guides | X. Lower Wheel Shaft Fasteners |
| K. Rip Fence Assembly | Y. Drive Belt Tension Release Nut |
| L. Front Rail for Rip Fence | Z. Motor |
| M. Lower Blade Guides and Guard | |
| N. Lower Door Locking Knob | |

See pages 24 to 27 for Parts Diagrams and Parts Lists

CONTENTS OF PACKAGE

Model 10-306 10" Deluxe Bandsaw is shipped complete in one box.

UNPACKING, CHECKING CONTENTS & CLEAN-UP

1. Carefully remove all contents from the shipping carton. Compare the contents with the list of contents to make sure that all of the items are accounted for, before discarding any packing material. Place parts on a protected surface for easy identification and assembly. If any parts are missing or broken, please call RIKON Customer Service (877- 884-5167) as soon as possible for replacements. **DO NOT** turn your machine ON if any of these items are missing. You may cause injury to yourself or damage to the machine.
2. Report any shipping damage to your local distributor. Take photographs for any possible insurance claims.
3. With the help of another person, carefully lift the Bandsaw from the packaging and place it on a level floor.
4. Clean all rust protected surfaces with ordinary house hold type grease or spot remover. Do not use; gasoline, paint thinner, mineral spirits, etc. These may damage painted surfaces.
5. Apply a coat of paste wax to the table to prevent rust. Wipe all parts thoroughly with a clean dry cloth. Be careful, as the pre-installed bandsaw blade has sharp teeth and may cause injury if touched.
6. Set packing material and shipping carton aside. Do not discard until the machine has been set up and is running properly.

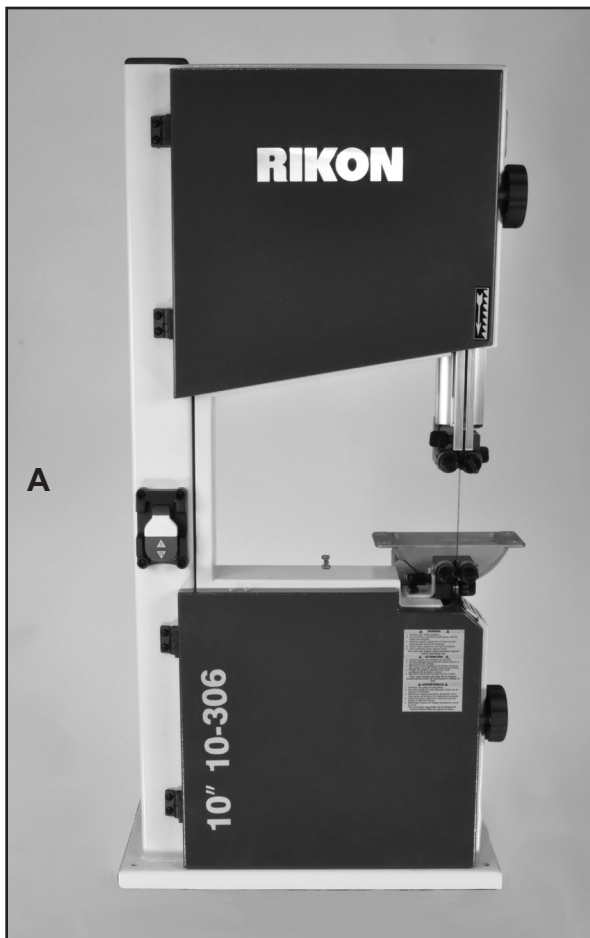

LIST OF LOOSE PARTS

- A. Bandsaw Frame Assembly
- B. Table with Blade Insert
- C. Bolts (4) and Lock Washers (4) to attach table to trunnion on bandsaw frame

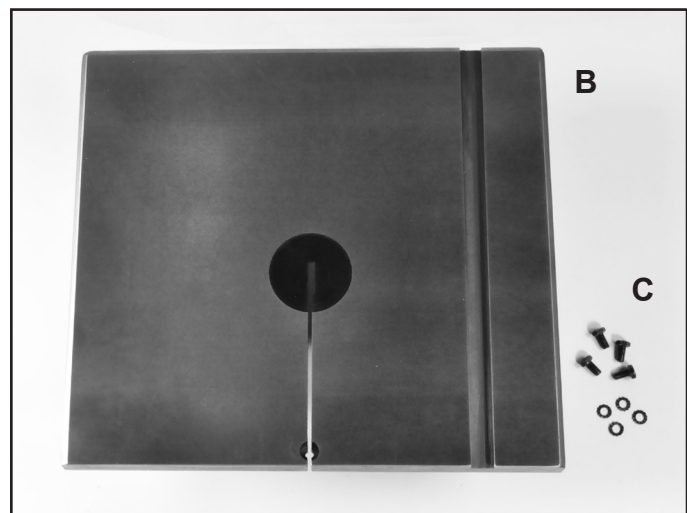

CONTINUED ON PAGE 9

CONTENTS OF PACKAGE

LIST OF LOOSE PARTS continued

- D. Rip Fence
- E. Rip Fence Carrier Assembly
- F. Front Rail for Rip Fence Carrier Assembly
- G. Knob for Mounting Front Rail (2)
- H. Table Leveling Bolt, Washer & Knob
- I. Rip Fence Storage Hanger & Screws (2)
- J. Blade Tensioning Knob
- K. Wrench: 10 mm
- L. Hex Wrenches; 2.5, 3, 5, 6 mm

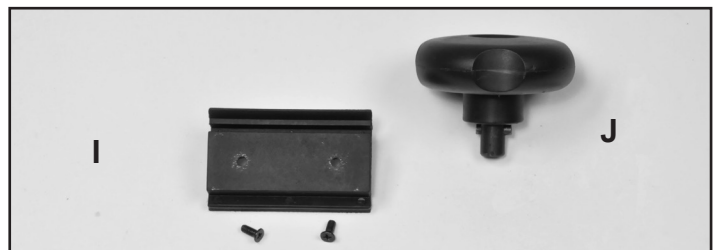
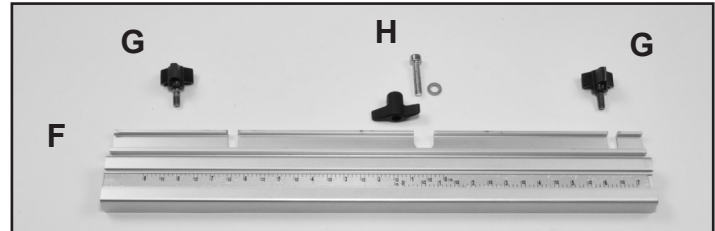

Additional Tools required - not supplied

- #2 Phillips Screwdriver
- 90° Square

INSTALLATION

MOVING & INSTALLING THE BANDSAW

CAUTION The bandsaw is heavy - over 77 lbs! It is best to assemble the machine near the area where it will eventually reside.

When moving or positioning an assembled bandsaw, DO NOT use the table or upper blade guard assemblies as this may damage the machine. Move the bandsaw by grasping the support column and lower frame or base which are all welded together for rigidity. The bandsaw can also be moved by laying it down on the back/left side of the column so that the table assembly is not compromised. Be careful not to damage the rip fence hanging panel on the column edge.

1. Carefully remove the machine from the shipping carton. See above instructions on handling the saw.

2. Position the machine on a solid, level foundation (workbench or stand) that is located in an area that has ample space in front, right side and in back of the bandsaw for cutting large or long material.

3. Align the machine so that during use, the material being cut will not face aisles, doorways, or other work areas that bystanders may be in. Do not locate or use the machine in damp or wet conditions.

4. Once in place in your shop, level the machine with spacers so that it does not move during use. If possible, secure it with lag screws (not supplied) using the 4 holes in the machine's base.

5. For best power and safety, the bandsaw should be plugged directly into a dedicated grounded electrical outlet that is within the supplied cord length of the machine. The use of an extension cord is not recommended. See safety information section.

ASSEMBLY

WARNING THE MACHINE MUST NOT BE PLUGGED IN AND THE POWER SWITCH MUST BE IN THE OFF POSITION UNTIL ASSEMBLY IS COMPLETE.

NOTE: Parts referenced throughout the manual refer to the key numbers of the Parts Diagrams and Parts Lists on pages 24 to 27.

The machine is supplied partly assembled. Prior to use, the following items have to be installed: Table, Fence Guide Rail, Rip Fence & Carrier, Blade Tension Knob, and Rip Fence Holder.

TABLE ASSEMBLY

1. Mount the table (Part #124) in place on the trunnion. Do this from the rear of the machine, so that it is easier to fit the pre-installed blade through the slot in the table. FIG. 1.

2. Attach the table to the trunnion with the four Hex Bolts and Washers (#129, 128). Install two bolts to the right of the blade, hand tightened only. Then loosen the trunnion with the Wing Nut (#113), tip the table to 45 degrees and install the two bolts to the left of the blade. DO NOT fully tighten the bolts at this time. Return the table to the horizontal position. FIG. 2.

NOTE: Before finally secured in position, the table can be slightly moved, left and right. Check to make sure that the table's miter gauge slot is parallel to the side of the saw blade. This will provide a true cut when ripping stock. Set a thin metal ruler against the side of the saw blade. Make sure that it is not touching the saw's teeth, which can angle the ruler. Measure the distance from one end of the ruler to the miter gauge slot. FIG. 3. Then measure the same distance from the other end of the ruler to the miter gauge slot. Compare these two measurements and angle the table as necessary until the distances are the same.

3. Once the table is aligned parallel to blade, tighten all four of the installed bolts to secure the table in place. See page 12 for additional table adjustment information.

TABLE LEVELING BOLT ASSEMBLY

1. To help keep the two sides of the table level at the slot area, a Hex Socket Head Bolt (#125) with Washer and Wing Nut (#126, 127) are used.

2. Install the Bolt through the front hole in the table top, and secure it in place from the underside of the table with the washer and wing nut. FIG. 4.

NOTE: The leveling bolt should be kept in place at all times, and only removed when the saw blade is changed.



FIGURE 1

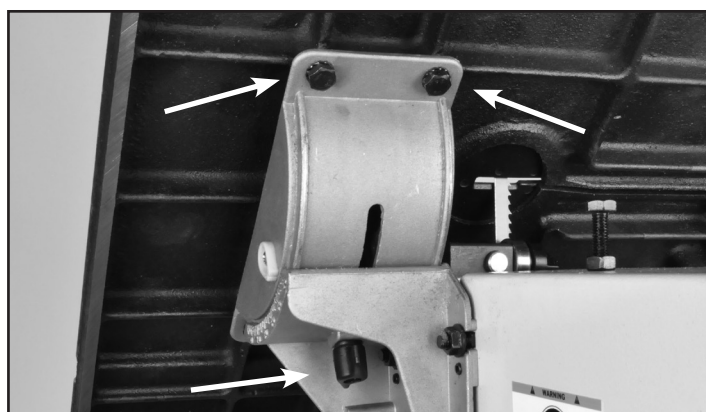

FIGURE 2

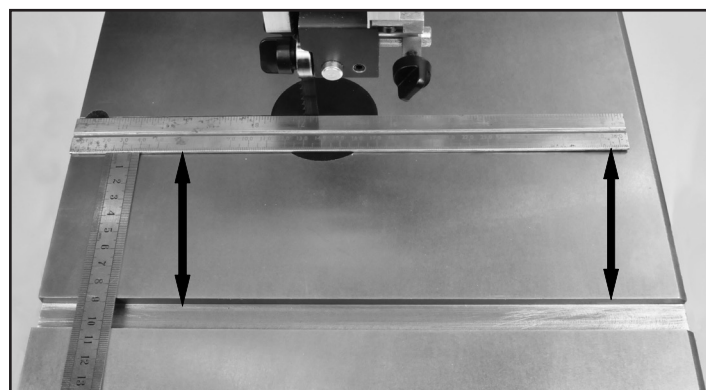

FIGURE 3



FIGURE 4

ASSEMBLY

INSTALL GUIDE RAIL FOR FENCE

1. Position the fence's Guide Rail (#96) onto the front table edge. The guide rail's front lower edge, with 3 cut-out areas, fits under the table. The center cut-out gives access to the table leveling bolt and wing nut. The 2 outer cut-out areas are where the guide rail will be fastened to the table.
2. Secure the guide rail to the table with the two Star Knob Screws (#97). FIG. 5.

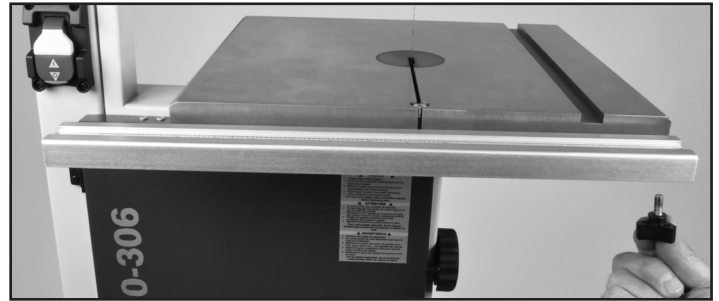

FIGURE 5

RIP FENCE ASSEMBLY

1. Install the Fence Carrier Assembly (#99-111) onto the fence's Guide Rail. The Carrier's front, Lever Handle (#101) should be lifted up, released, to allow the Carrier (#100) to fit onto the top of the guide rail. Once in place, move the carrier's front lever handle down to lock the carrier in position on the guide rail. FIG. 6 A.
2. The Fence (#106) attaches to the carrier by sliding it onto the steel Locking Frame Bar (#105). FIG. 6 B. There are two 'T' slots in the fence that the bar will slide into. FIG. 6 V & H.
 - Slot V is to use the fence in a *vertical* position.
 - Slot H is to use the fence *horizontally*.
3. Loosen the two Nuts (#110) on the left side of the carrier to free the Locking Bar so that the fence can be easily slid onto the bar. Once in place, secure the fence to the carrier by tightening the same 2 nuts which pulls the locking bar with attached fence back against the carrier.

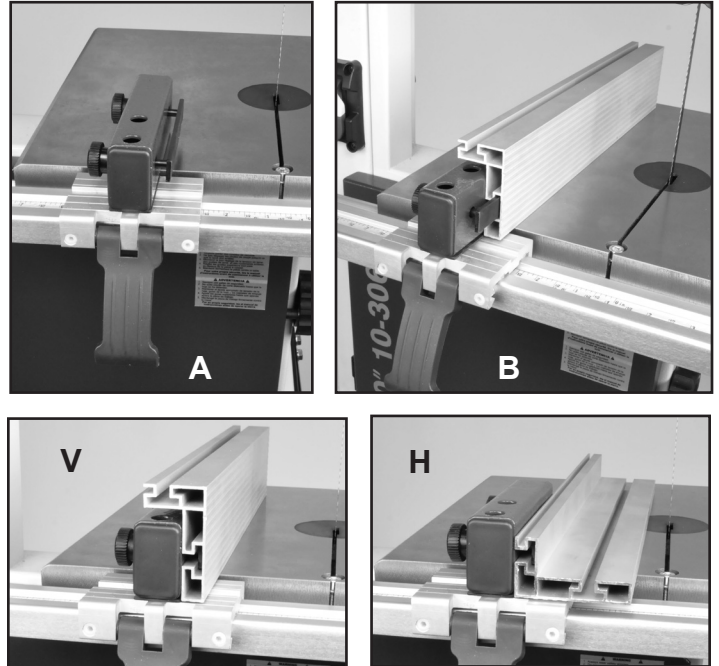

FIGURE 6

FENCE HOLDER ASSEMBLY

1. Install the Fence Storage Hanger Panel (#62) to the top, left side of the column with two Phillips Screws (#63). See Figure 7, which shows the proper position of the hanger's top and bottom lips. The wider, double lip should be at the top, the single lip at the bottom.

This hanger allows handy storage for the Rip Fence and Carrier Assembly when not in use.

2. To use, just slide the fence & carrier onto the hanger and lock it in place with the carrier's lever handle.
3. Reverse the process to remove the fence from the hanger.

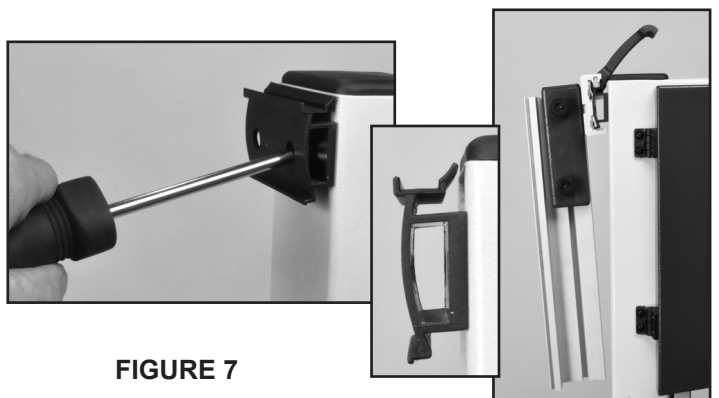

FIGURE 7

BLADE TENSION HANDLE

1. Place the Blade Tensioning Handle (#20) onto the Tension Rod end (#21) located at the top of the frame. FIG. 8.

See page 14 for Blade Tensioning Adjustments.

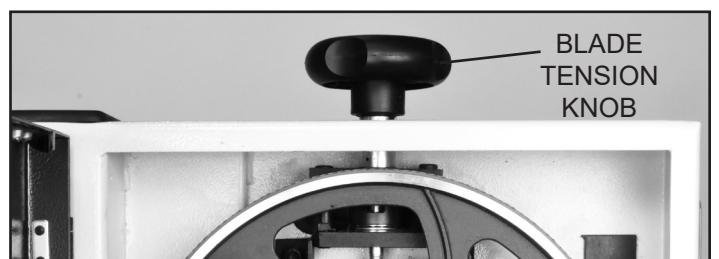

FIGURE 8

ASSEMBLY

To ensure sufficient, upright stability of the machine, it should be bolted to a bench, worktable or stand. For this purpose 6mm (1/4") holes are provided in the machine's base. FIG. 9. (Fasteners are not included).



FIGURE 9

This bandsaw has a 2-1/2" (64mm) dust port at the rear of the machine. FIG. 10. During use, connect the bandsaw to a suitable dust collector to eliminate sawdust from collecting inside the machine, on the wheels, blade guides etc..

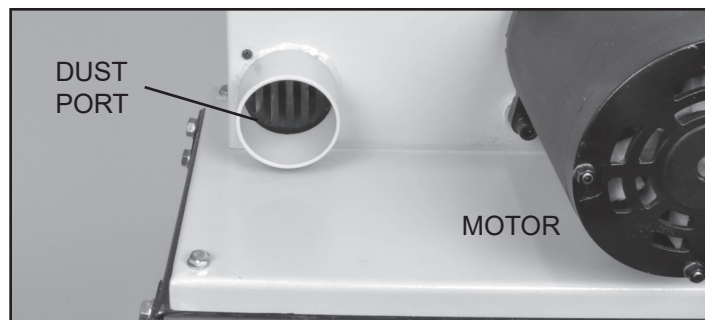

FIGURE 10

ADJUSTMENTS

CENTERING THE TABLE

If the bandsaw blade is not centered in the table during the initial table-to-trunnion assembly (see page 10), additional table positioning adjustments may be necessary.

1. Loosen the four Hex Flange Nuts (#116) that hold the lower trunnion and table to the bandsaw frame. FIG. 11.
2. Move the table sideways as required, until the saw blade runs through the center of the table insert.

SETTING TABLE SQUARE TO SAW BLADE

NOTE: Make sure that the table is not tilted left or right during this operation. Using a square, the table should be set 90° to the side of the blade. FIG. 12.

3. Make sure that the 90° Table Rest Bolt (#87) is not interfering with this process. Loosen the bolt's Locking Nut (#86) and screw the bolt downward, away from the underside of the table. FIG. 13.

3. Once the table is centered in the table inset and is square to the blade, tighten the four flange nuts that were loosened in step 1.

4. With the table secured in position, check that the table Angle Indicator (#120) reads zero degrees on the scale on the lower trunnion. Loosen the screw holding the indicator and reset if necessary to the zero degree reading. FIG. 11.

5. With the table secured in the 90° position, adjust the table rest bolt up or down, until it is in contact with the underside of the table.

6. Retighten the table rest's locking nut making sure that the 90° table angle setting is maintained. FIG. 13.

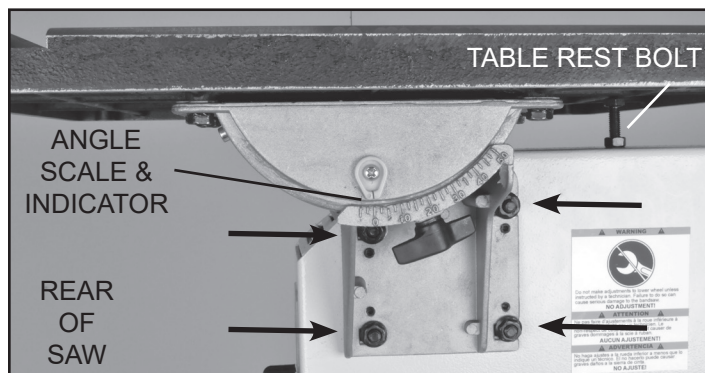

FIGURE 11

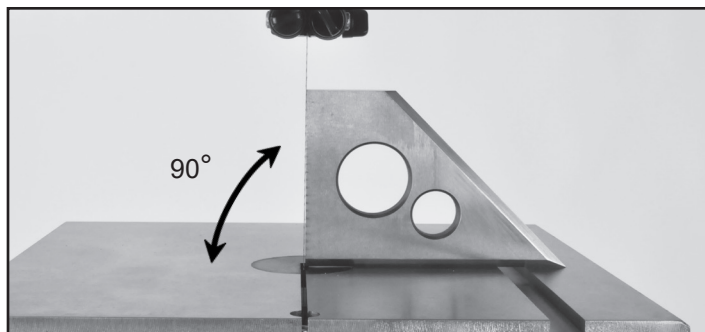

FIGURE 12

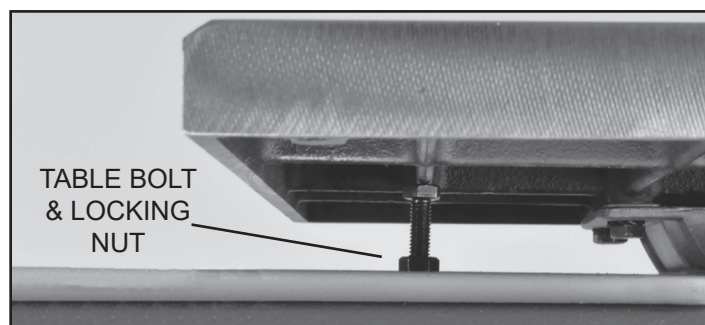

FIGURE 13

ADJUSTMENTS

SETTING THE TABLE SQUARE TO THE SAW BLADE'S BACK

While pre-set before shipping, if needed, the table may also be re-set at 90° to the back of the saw blade by adjusting the trunnion micro adjustment screws.

1. On the lower Trunnion Support (#115), *slightly* loosen the four Hex Flange Nuts (#116) whose bolts (#112) hold the support to the bandsaw frame. FIG. 14.
2. Set a square on the table and against the saw blade's back, flat edge.
3. Using the 2.5mm hex wrench, turn the rear trunnion micro adjusting hex screws (#116A) to adjust the table position. FIG. 14. Adjust the micro screws in pairs, top 2 or bottom 2, to adjust the table angle to the blade.
 - *Clockwise* moves the support away from the saw frame.
 - *Counterclockwise* moves the support towards the frame.
4. Check the table and blade angle for 90° and when achieved, re-tighten the flange nuts to secure the table in position.

TILTING THE TABLE

For bevel cuts, the table tilts 0 through 45 degrees.

1. To tilt the table, loosen the Wing Nut (#113) on the table trunnion. Set the table to the required angle and then tighten the wing nut to secure the table. FIG 15.

The trunnion features a Stop (#118) that adjusts to set the table angle at a precise 45° angle. FIG. 15 Inset.

NOTE: For critical angled cuts, it is recommended to verify the correct angle setting using an angle guide, or by making trial cuts in scrap wood.

ADJUSTING THE RIP FENCE

The locking pressure and angle of the rip fence has been factory-set with the two plastic Hex Screws (#99) on the front of the Fence Carrier (# 100). FIG. 16.

If adjustment is required, proceed as follows:

1. Position the fence assembly on the front Guide Rail (#98) and raise the cam action Fence Handle (#101) up to vertical position.
2. With the 3mm hex wrench, adjust the plastic hex screws clockwise to increase clamping pressure, counterclockwise to decrease clamping pressure. Note that these adjustments will also change the angle of the fence to the blade. Align the fence so it is parallel to the blade and miter gauge slot in the table top.
3. Press the handle down to clamp the fence assembly to the front guide rail to check the settings. Make further adjustments with the hex screws in small steps.

! WARNING THE MACHINE MUST NOT BE PLUGGED IN AND THE POWER SWITCH MUST BE IN THE OFF POSITION UNTIL ALL ADJUSTMENTS ARE COMPLETE.

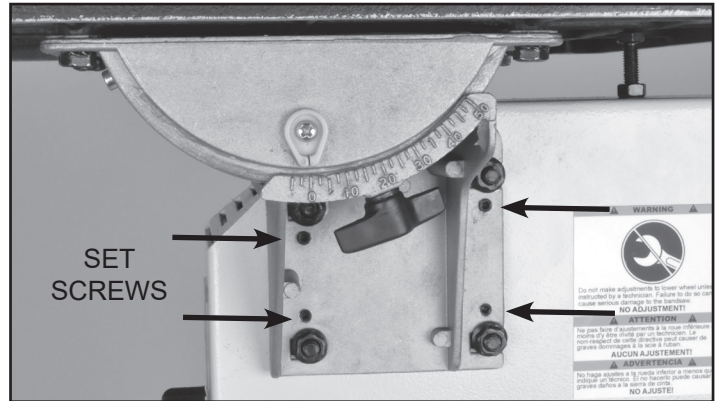

FIGURE 14

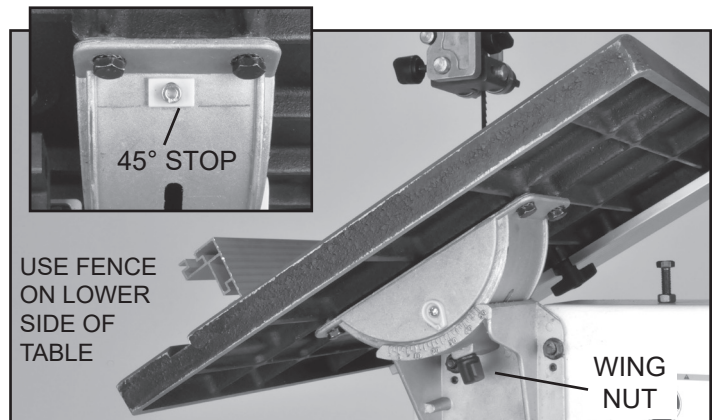

FIGURE 15

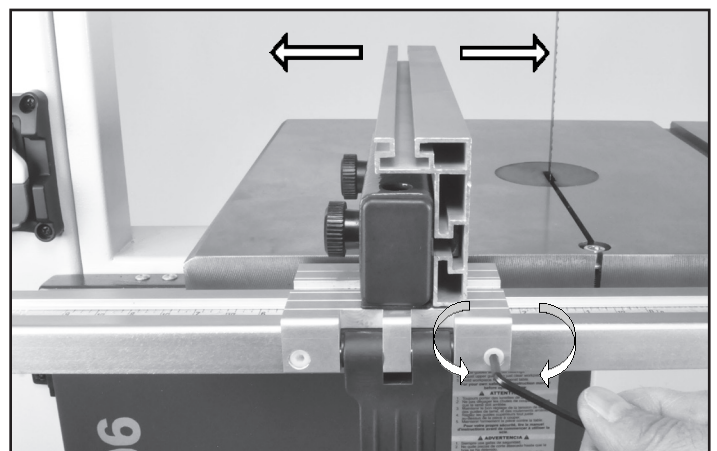

FIGURE 16

NOTE: Do not adjust the fence handle so that excessive pressure is exerted during operation - this may lead to deformation and failure of the fence clamping parts. Set the handle to apply just enough pressure to enable easy sliding on the rail and safe, secure operation during cutting.

ADJUSTMENTS

TRACKING THE SAW BLADE

WARNING Unplug the bandsaw. A blade is installed at the factory. It is recommended to check the blade tracking prior to use. Make sure the upper and lower blade guides are adjusted away from the blade.

1. Open both doors. At the rear of the machine, loosen the locking Wing Nut Knob (#66) by turning it counterclockwise. FIG. 17.

2. Turn the Blade Tracking Handle (#67) clockwise or counterclockwise, while at the same time carefully turning the Upper Wheel (#6) by hand. Check the tracking of the blade on the wheel through the side window (#72). Make at least three rotations of the wheel or until the blade tracks centered on the wheel. FIG. 18.

3. Once the blade runs centered, tighten the locking wing nut knob and close the doors. If tracking of the blade on the Lower Wheel (#156) is needed, see page 22.

NOTE: 1/8" (3.18mm) blades should be 0.018" to 0.020" gauge to reduce tracking issues common with this width.

NOTE: the lower wheel has been pre-set at the factory and any changes made to this wheel should be after thorough reading and understanding of the instructions. Failure to do so could damage the machine.

ADJUSTING THE BLADE TENSION

CAUTION Always tension the blade with the rear Quick Release Lever (#23) in the "ON" position. Failure to do so could result in lack of blade tension or tension failure. FIG. 19.

NOTE: Release / turn 'OFF' the Tension Lever only to change the blade, or to prolong the life of the blade when the saw is not in use for extended periods.

1. To adjust the blade tension, turn the Blade Tension Handwheel (#20) on the top of the saw. FIG. 19.
2. To tighten the tension of the blade, turn the handwheel clockwise. To reduce blade tension, turn the handwheel counterclockwise.

General Rule for blade tension: With the saw unplugged, the blade guard up and the blade guides moved away from the blade, the saw blade should deflect about 1/4" when pressed with a finger to the side of the blade.



FIGURE 17



FIGURE 18

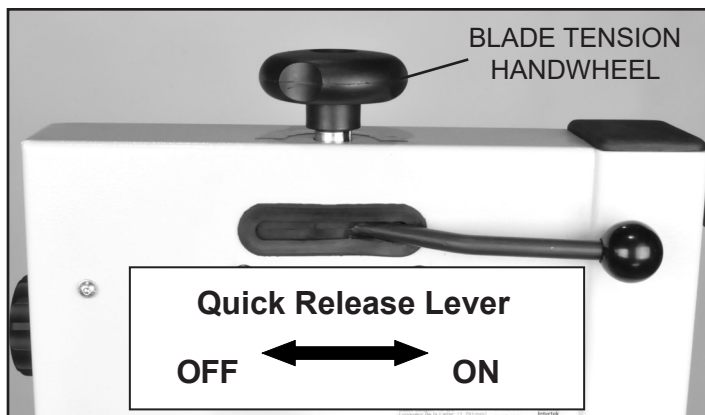

FIGURE 19

CHANGING THE BANDSAW BLADE

This bandsaw is factory-equipped and set with a general-purpose wood cutting blade. To change the saw blade, the following procedure must be followed:

WARNING Unplug the machine from the electrical supply so it will not accidentally turn on while changing the saw blade.

1. Remove the Rip Fence and Guide Rail from the table. FIG. 20, A.
2. Remove the Table Leveling Bolt from the blade slot at the front of the table. FIG. 20, B.
3. Open the top and bottom wheel doors.
4. Move the Upper and Lower Blade Guides away from the sides and rear of the saw blade. FIG. 20, C, D. See pages 15 and 16 for details.

CONTINUED ON THE NEXT PAGE

ADJUSTMENTS

5. Release the blade tension by moving the quick release Tension Lever from right to left. FIG. 19.

6. Remove the saw blade from the top wheel then feed it through the upper blade guides (C), slot in the table (E), lower blade guides (D), out of the left slot in the column of the machine (F), and off of the bottom wheel.

CAUTION Be careful not to cut yourself on the sharp saw teeth. Wear gloves for protection.

7. When installing the new blade, reverse the steps in item 6 above. Ensure that the blade teeth are pointing downwards and towards you at the position where the blade passes through the table.

8. Center the blade on both wheels.

9. Re-tension the new blade by moving the quick release lever back to the ON position, FIG. 19, and check the blade tracking. The blade should run in the center of the wheels. Refer to "Tracking the Saw Blade" on page 14 for details.

10. Close and lock both the wheel doors.

11. Re-install the Table Leveling Bolt, and front Guide Rail.

12. Adjust the blade guides as described below and on pages 16 and 17.

13. Reset the blade tension as described on page 14.

14. Reconnect the power supply to resume bandsaw use.

ADJUSTING THE BLADE GUIDES

This deluxe bandsaw features quick-adjusting, spring loaded, ball bearing blade guides for fast and easy setting to the blades. With the bandsaw blade properly centered on the drive wheels, the guide bearings can then be set. To adjust the blade guides:

Upper Guides:

1. Position the right and left roller guides about 1/32" to the blade sides. First, loosen their front Lock Handles (#134, FIG. 22, A) by twisting them counterclockwise. The Guide Shafts (#154) that hold the guide bearings are spring loaded! To move the guides towards the blade, simply push the ends of the guide shafts (B), or use the front lock handles to pull the guides towards the blade. Lock the guides in place by turning them clockwise. FIG. 22.

2. The guides should be approximately 1/16" behind the gullets of the saw blade. If they need to be moved, loosen the back Clamp Handle (#134, FIG. 22 & 23, D) and move the Upper Guide Block (#153, E) that holds the guides so that the guides are properly positioned behind the blade gullets. Re-tighten the handle when done. FIG. 23.

WARNING THE MACHINE MUST NOT BE PLUGGED IN AND THE POWER SWITCH MUST BE IN THE OFF POSITION UNTIL ALL ADJUSTMENTS ARE COMPLETE.

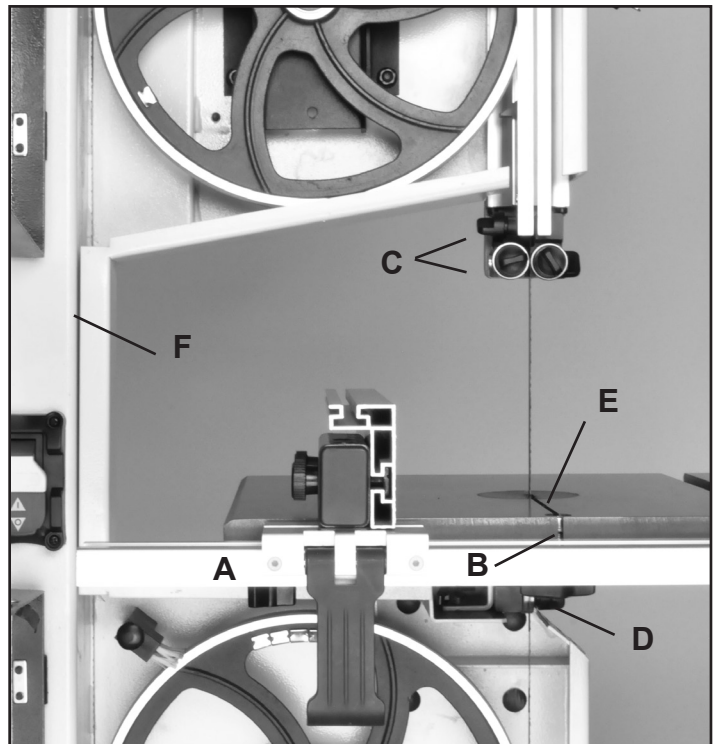

FIGURE 20

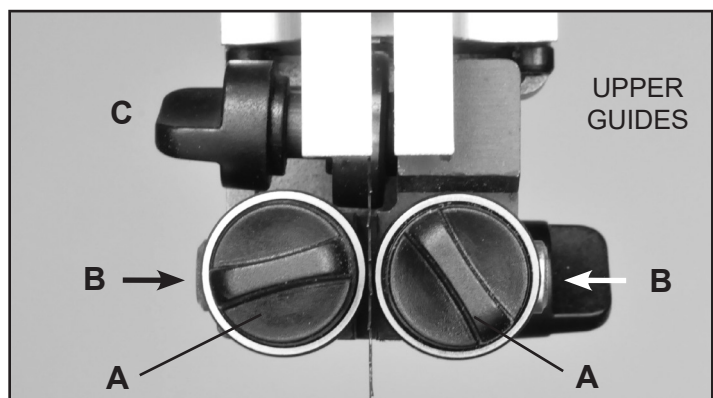

FIGURE 22

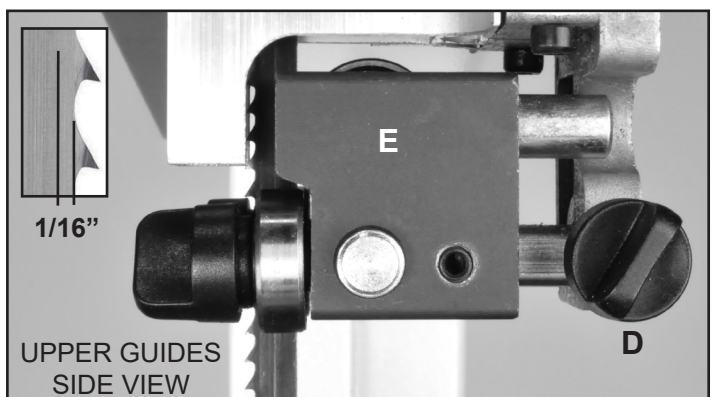

FIGURE 23

ADJUSTMENTS

3. Set both bearing guides to within $1/32$ " of the saw blade - about the same thickness of a business card. Do not set the guides so they touch the sides of the blade, as this will adversely affect the life of the saw blade and bearings.

4. Adjust the rear bearing guide (FIG. 24, F) to be just clear of the back of the saw blade. Release the guide's Clamp Handle (#151, C) and move the rear guide towards the blade by pushing the end of the Rear Guide Shaft (#132, G). Tighten the handle when done. FIG. 24.

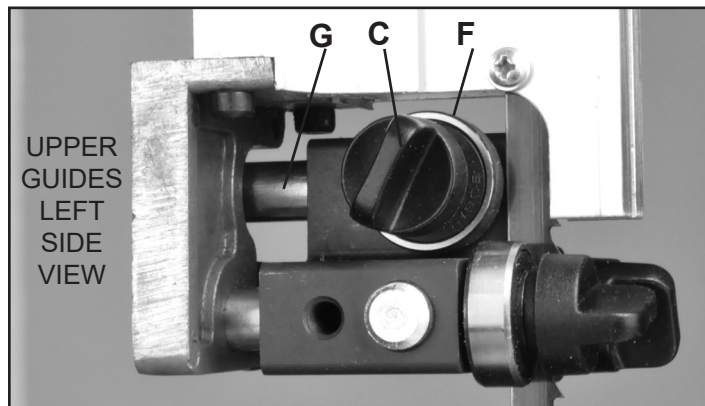

FIGURE 24

Lower Guides:

Adjusting the lower ball bearing guides, that are below the table, is similar to the steps taken for the upper guides.

1. Position the right and left roller guides close to the blade. Loosen the front Lock Handles (FIG. 25, A). Move the guides towards the blade by pushing the ends of the Guide Shafts (B), or use the front lock handles to pull the guides towards the blade. Lock the guides in place. FIG. 25

2. The guides should be approximately $1/16$ " behind the gullets of the saw blade. If they need to be moved, loosen the spring loaded Lever Handle (#43, FIG. 26, C), located to the left of the Lower Guide Block (#47, D), and move this block that holds the guides so that the guides are properly positioned behind the blade gullets. Re-tighten the lever handle when done.

3. Set both bearing guides to within $1/32$ " of the saw blade - about the same thickness of a business card. Do not set the guides so they touch the sides of the blade, as this will adversely affect the life of the saw blade and bearings.

4. Adjust the rear bearing guide to be just clear of the back of the saw blade. Release the guide's Locking Handle (#49) (FIG. 27, E) and move the rear guide towards the blade with the locking handle or by pushing the end of the Rear Guide Shaft (#53, F). Tighten the handle when done.

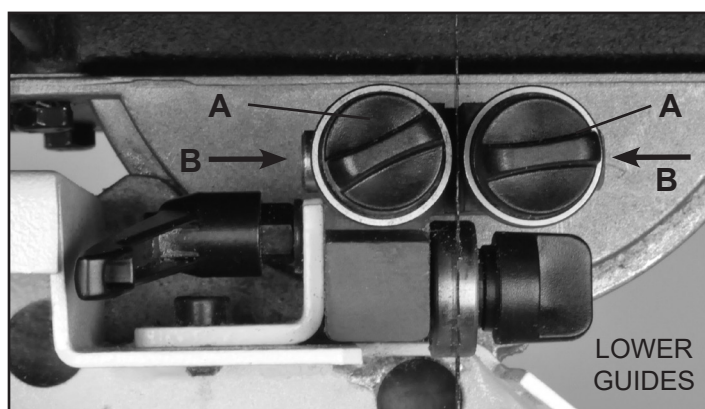

FIGURE 25

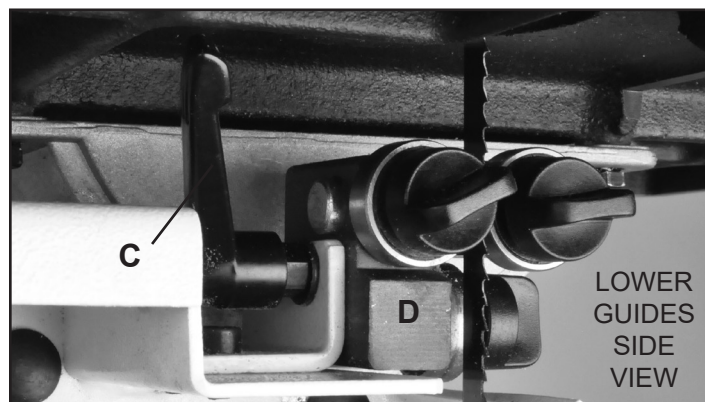

FIGURE 26

ADJUSTING THE BLADE GUIDES & GUARD

NOTE: Before cutting, set the upper guide bearings approximately $1/4$ " above the top surface of the work piece. This will give the best blade control. FIG. 28.

1. Loosen the Guidepost Lock Knob (#141, FIG. 29, A) and turn the Guidepost Handle (#140, FIG. 29, B) to raise or lower the guide post/upper blade guide assembly to the desired height above the table or work piece. FIG. 28 & 30.

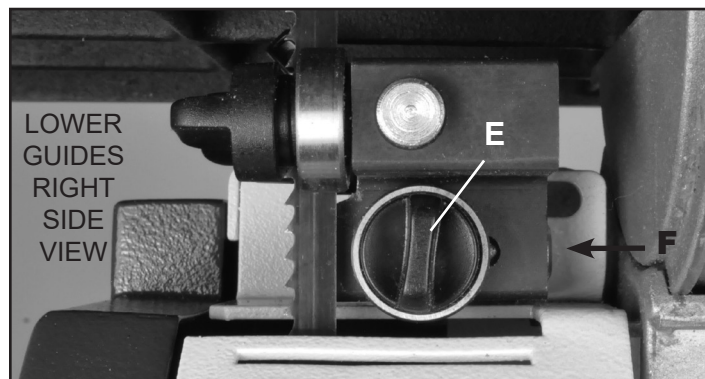

FIGURE 27

CONTINUED ON THE NEXT PAGE

ADJUSTMENTS

2. When the guide bearings are in proper position, tighten the guidepost lock knob loosened in the previous step.

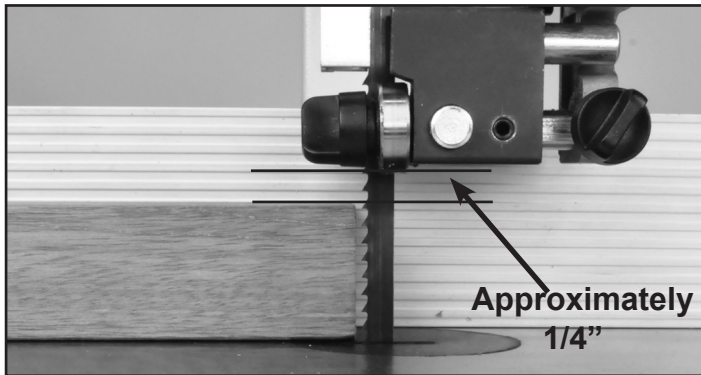

FIGURE 28



FIGURE 29

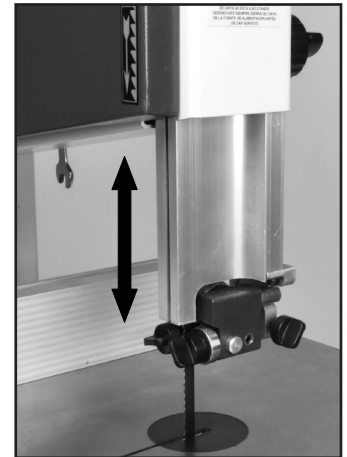

FIGURE 30

ADJUSTING THE FENCE ON THE CARRIER

The fence can be changed from a vertical position to a horizontal position, or from its mounting on the left side of the blade to the right with simple adjustments of the carrier's handles and hardware.

To change the fence from vertical to horizontal:

1. Loosen the two side Knobs (#110, FIG. 31, A) which hold the Fence (#106) against the Fence Carrier (#107, B).
2. Slide the fence forward to remove it from the carrier's Locking Frame Bar (#105, FIG. 32, C).
3. Rotate the fence 180°, turn it down to its horizontal position and slide it back onto the carrier. The short face of the fence is slotted to mount on the frame bar. FIG. 33.
4. Once in place, retighten the two side knobs to secure the fence in position on the carrier.
5. Confirm that the fence is parallel with the blade and miter gauge slot, and make corrections for 'drift' if needed per instructions on page 13.

To change the fence from the left side of the carrier to the right side for using the rip fence to the right of the blade:

1. Loosen the two side Knobs (#110, FIG. 31, A) which hold the Fence against the Fence Carrier (#107, B).
2. Slide the fence forward to remove it from the carrier's Locking Frame Bar (#105, FIG. 32, C). Move the carrier on the front rail to the right side of the table and blade.
3. Fully unscrew the side knobs from the frame bar and reassemble the parts on the opposite, left side of the carrier. Then rotate the fence 180° end-to-end and slide it back onto the carrier. FIG. 34 & 35.

CONTINUED ON PAGE 18

WARNING THE MACHINE MUST NOT BE PLUGGED IN AND THE POWER SWITCH MUST BE IN THE OFF POSITION UNTIL ALL ADJUSTMENTS ARE COMPLETE.

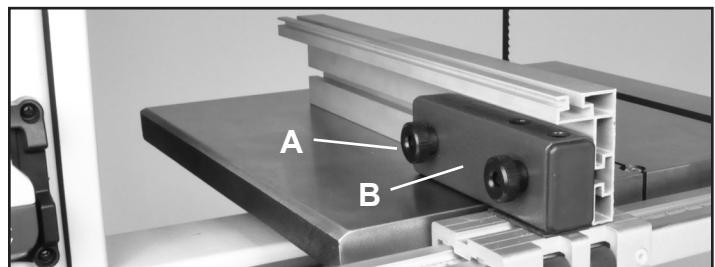

FIGURE 31

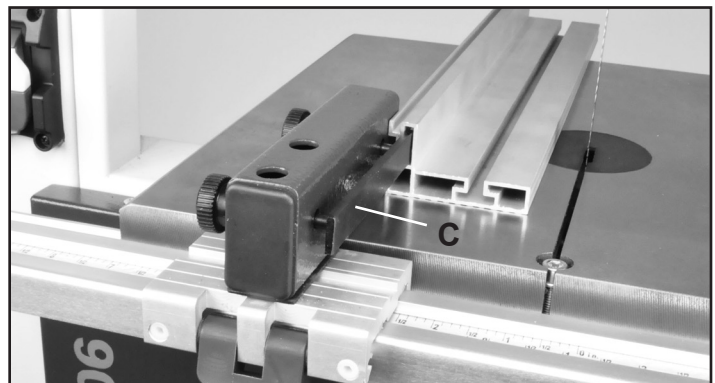

FIGURE 32

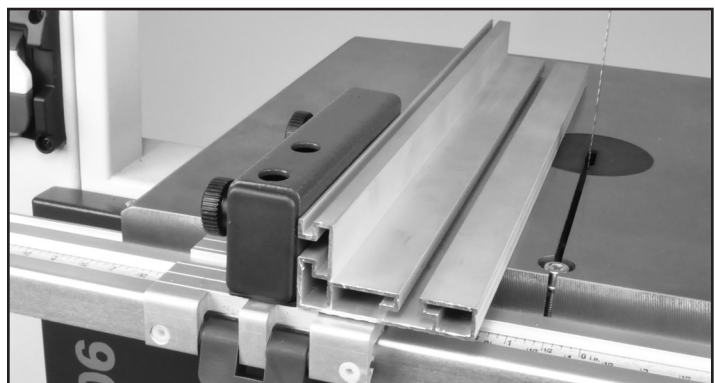

FIGURE 33

ADJUSTMENTS

CONTINUED FROM PAGE 17

4. Once in place, retighten the side knobs to secure the fence in position on the carrier. FIG. 35.

5. Confirm that the fence is parallel with the blade and miter gauge slot, and make corrections for 'drift' if needed per instructions on page 13.

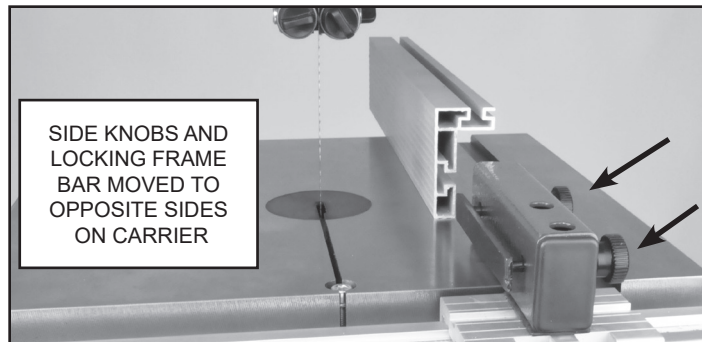

FIGURE 34

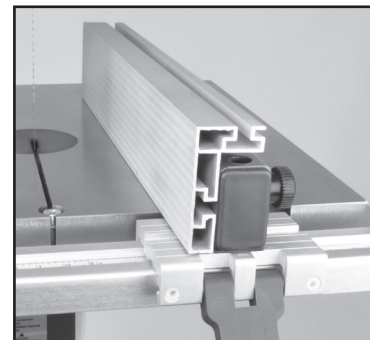

FIGURE 35

CHANGING THE BLADE SPEED & ADJUSTING THE DRIVE BELT TENSION

This Bandsaw has two blade speeds, high speed (3,280 ft/min) and low speed (1,515 ft/min). See below.

NOTE: The bandsaw is shipped in the high speed mode.

The lower bandsaw drive wheel has two integral "multi-vee" form pulleys (#155), and the motor shaft has a twin multi-vee form pulley (#32). The multi-vee Belt (#33) passes around the wheel pulley and the motor pulley.

For the **HIGH SPEED** (3,280 ft/min), the belt should be installed on the rear pulleys of both the motor and the wheel. See FIG. 37. Pulley positions 2 to 4.

The high speed setting is the standard for all around sawing needs of woods and composites.

For the **LOW SPEED** (1,515 ft/min), the belt should be installed on the front pulleys of both the motor and wheel. See FIG. 37. Pulley positions 1 to 3.

The low speed setting is best for cutting extra hard material - wood, plastics, and non-ferrous metals. The correct blade type is necessary for clean and effective cutting of these materials.

Changing blade speeds and adjusting belt tension is done by pivoting the rear Motor (#88) and the Pulley (#32) which is mounted to its shaft.

1. Loosen the top motor mount Screw (#77) and pivot the motor to release tension on the drive belt. FIG. 36, A.
2. Change the belt position for the blade speed desired.
3. Tension the drive belt so there is about 3/8" to 1/2" deflection. DO NOT over tension the belt as this can put excessive, damaging pressure on the belt, pulleys and motor. FIG. 38.



FIGURE 36

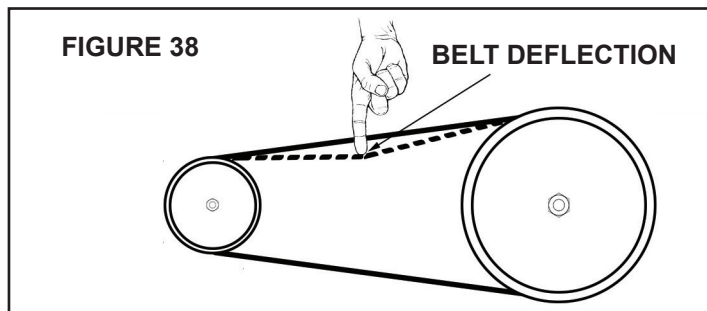
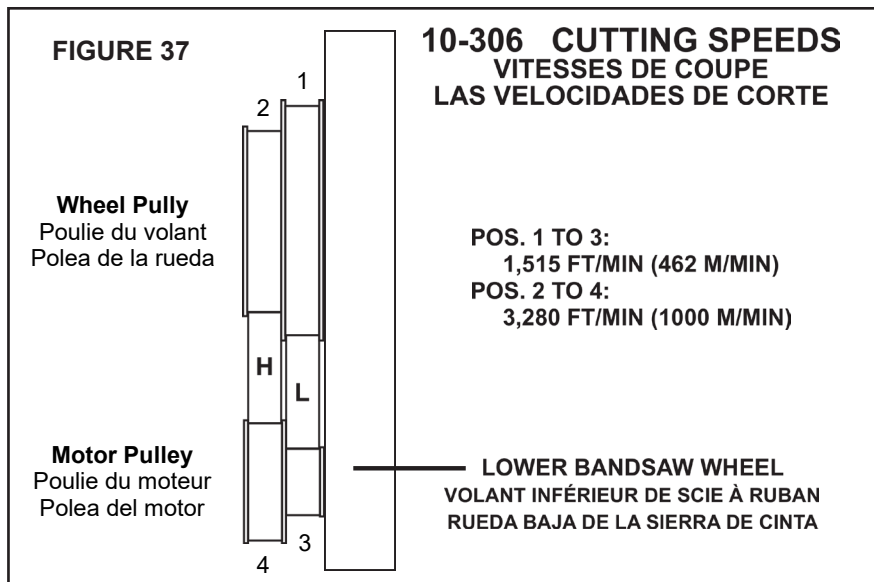

4. Tighten the motor mount screw to secure the motor in place and set the drive belt tension.

ADJUSTMENTS

WARNING THE MACHINE MUST NOT BE PLUGGED IN AND THE POWER SWITCH MUST BE IN THE OFF POSITION UNTIL ALL ADJUSTMENTS ARE COMPLETE.

CHANGING THE MOTOR DRIVE BELT

Before changing the belt, make sure that the bandsaw is unplugged from the power source. To change the drive belt:

1. Release the tension on the bandsaw blade (See pages 14 & 15) and move the blade off of the lower wheel, or take the blade totally off from the saw. FIG. 39.

2. Remove the tension from the drive belt by loosening the top Motor Mount Screw (#77) and pivoting the motor. See FIG. 36. Take the old belt off of the two pulleys.

3. Take the Lower Wheel (#34) off of the saw by removing the Retaining Ring (#11) that is in the middle of the lower wheel. **NOTE:** A set of 'Snap Ring' or 'C-Clip' Pliers is required to do this. (Not included). Carefully pull the wheel off the lower shaft (#80).

4. Install the new belt and reverse the process outlined above. Make sure that the ribs in the drive belt are seated correctly in the pulley before reassembling and tensioning the drive belt. Tension the drive belt until there is 3/8" to 1/2" of deflection. See page 18.



FIGURE 39

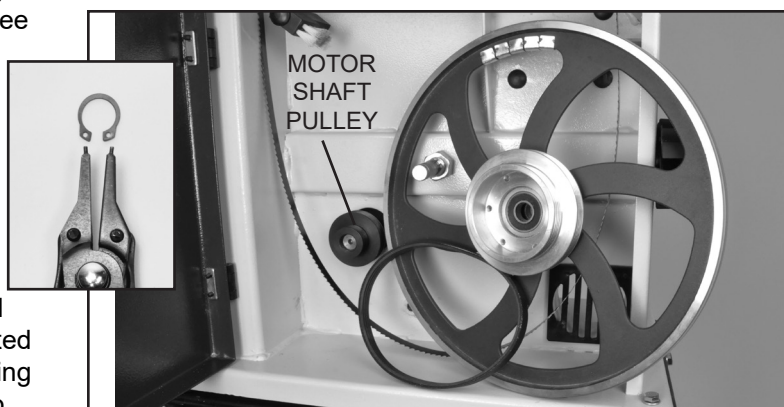

FIGURE 40

CHANGING BANDSAW TIRES

Use a putty knife to get underneath the tire and pull it up and away from the wheel. Work the putty knife all the way around the wheel to loosen the tire. Then, use the putty knife as leverage to flip the tire over and off of the wheel. Clean the inside of the groove, removing any dirt, debris or cement with lacquer thinner.

Soak the replacement tire in warm water to make it more flexible. Dry the tire, and while it is still warm, lay it on top of the wheel. Start by setting the tire into the wheel groove at the top of the wheel. Using a putty knife, work the new tire around the wheel, making sure not to slice the tire. If rubber cement is to be used as a binder, make sure to distribute it evenly. Having high spots between the wheel and the tire will cause a vibration and effect blade tracking.

ON/OFF SWITCH

The ON/OFF Locking Switch needs to have the yellow, safety key inserted before the switch can be used. This feature prevents unauthorized use of the bandsaw. FIG. 41.

To operate the saw, pull out the bottom of the paddle switch to turn the saw 'ON'. There should be a 'click' to indicate the 'ON' contact is made. Once work is finished, hit the bottom of the red safety paddle switch to turn the saw 'OFF'.

CAUTION Never walk away from the bandsaw when it is running. If the saw is not to be used for an extended length of time, always unplug the saw from the power supply, remove the safety key from the switch and release the tension on the blade.



FIGURE 41

OPERATION

⚠ WARNING Before starting, check if any part of your bandsaw is missing, malfunctioning, has been damaged or broken... such as the motor switch, guides, fence assembly, a safety device or the power cord. Turn the bandsaw off and unplug it until the particular part is properly repaired or replaced.

The saw blade cuts on a continuous downstroke. To avoid injury when hands are unavoidably near to the saw blade, they should be placed on either side of the blade, not in line with it. Use a push stick whenever possible when working in close proximity to the saw blade.

Start the bandsaw by turning the lock switch 'on' and wait for the bandsaw to come to full speed before starting to cut. Never start the bandsaw with the workpiece in contact with the saw blade.

Slowly feed the workpiece towards the saw blade, putting only light pressure on it. With both hands, firmly hold the workpiece down on the table, and slowly feed it towards the saw blade.

For best results the saw blade must be sharp. A dull blade will not cut correctly, especially when straight cutting, and causes excess pressure to be applied on the rear guide bearings.

Select the right saw blade for the job, depending on the thickness of the wood the cut to be made. The thinner and harder the wood, the finer the teeth of the saw blade. Use a fine tooth blade for cutting sharp curves. See page 30 for more information on blades.

The machine is especially suited for cutting curves, but will also make straight cuts. Do not attempt to turn the workpiece without pushing it, as this may cause the workpiece to get stuck, or the saw blade to bend.

The rip fence is to enable safe and accurate straight cuts of the workpiece, usually in the same direction as the grain of the timber.

Use a miter gauge (available separately) for safe and accurate crosscut or angle cutting of work pieces.

The tilting table is used for bevel cuts.

⚠ WARNING When sawing with the rip fence and a tilted table, the rip fence must be installed on that side of the table which is tilted downward.

SEE PAGES 3 - 6 FOR ADDITIONAL INSTRUCTIONS ON USING THE BANDSAW

MAINTENANCE

⚠ WARNING To avoid injury due to unexpected starting, before cleaning or carrying out maintenance work, turn the switch 'OFF' and disconnect the bandsaw from the power source.

Regular maintenance of the bandsaw will prevent unnecessary problems.

1. To avoid a build-up of wood dust, regularly clean all parts of the machine using a soft cloth, brush or compressed air. A general cleaning should be done after every use to avoid future problems and ensure the machine is in ready condition for the next time it is used.

WARNING: If blowing sawdust, wear proper eye protection to prevent debris from blowing into eyes. Avoid using high pressure near ball bearings seals as this may weaken the seals and allow lubricant to leak out, or force contaminants into the bearing.

2. Never use water or other liquids to clean the bandsaw. Use a dry brush or clean dry cloth.

3. Keep the outside of the machine clean to ensure accurate operation of all moving parts and prevent excessive wear.

4. Keep the table free of resin and rust. Clean it regularly with a non-flammable solvent, then coat with a light film of dry lubricant spray, or wax, to enhance passage of workpiece on/over the table.

WARNING: When cleaning or working on the table, avoid the risk of personal injury by cuts that may result from touching the bandsaw blade's sharp teeth!

5. Keep the guide bearings free of dust, and clean the guide bearing assemblies frequently.

6. Keep the ventilation slots of the motor clean to prevent it from overheating.

7. Keep the inside of the machine (near the saw blade, etc.) clean to prevent accumulation of dust. Use dust collection, if possible.

8. To prolong the life of the saw blade, when the bandsaw is not in use for extended periods, release the saw blade tension. Before reusing the bandsaw, ensure that the blade is re-tensioned and tracking is checked.

ELECTRICAL



This machine must be grounded. To avoid electrocution or fire, any repairs to electrical system should be done only by a qualified electrician, using genuine replacement parts. See page 5 for additional electrical information.

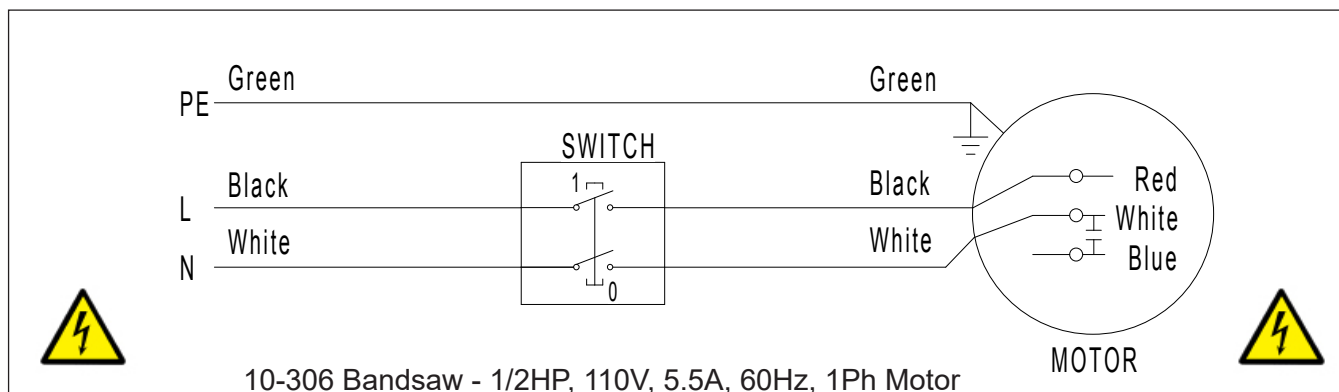

TROUBLESHOOTING

| PROBLEM | DIAGNOSIS | REMEDY |
|---|---|---|
| The machine does not work when switched on. | <ol style="list-style-type: none"> 1. No power supply. 2. Defective switch. 3. Defective motor. | <ol style="list-style-type: none"> 1. Check the cable for breakage. 2. Replace the lock switch. 3. Defective motor. |
| The saw blade does not move with the motor running. | <ol style="list-style-type: none"> 1. The blade tension knob has not been tightened. 2. The blade has come off one of the wheels. 3. The saw blade has broken. 4. The drive belt has snapped. | <ol style="list-style-type: none"> 1. Switch off the motor, tighten the blade tension knob. 2. Open the doors and check. 3. Replace the blade. 4. Replace the belt. |
| The saw blade does not cut in a straight line. | <ol style="list-style-type: none"> 1. Rip fence for cutting not used. 2. Feed rate too fast. 3. The blade teeth are dull or damaged. 4. Blade guides not suitably adjusted. | <ol style="list-style-type: none"> 1. Use a rip fence. 2. Put light pressure on the workpiece. Make sure the saw blade does not bend. 3. Try a new saw blade. 4. Adjust the blade guides (see ADJUSTMENT instructions). |
| The saw blade does not cut, or cuts very slowly. | <ol style="list-style-type: none"> 1. The teeth are dull, caused by cutting hard material or long use. 2. The saw blade was fitted the wrong way on the bandsaw. | <ol style="list-style-type: none"> 1. Replace the saw blade, use a 6 T.P.I. saw blade for wood and soft material. Use a 14 T.P.I. saw blade for harder materials. A 14 T.P.I. saw blade always cuts slower due to the finer teeth and the slower cutting performance. 2. Fit the saw blade correctly. |
| Sawdust builds up inside the machine. | This is normal | Clean the machine regularly. Open the doors and remove the sawdust with a vacuum cleaner. |
| Sawdust inside the motor housing. | This is normal | Clean the ventilating slots of the motor with a vacuum cleaner. From time to time remove the sawdust to prevent it from being drawn into the housing. |
| The machine does not cut at 45 or 90 degrees. | <ol style="list-style-type: none"> 1. The table is not at right angles to the blade. 2. The saw blade is dull or too much pressure was put on the workpiece. | <ol style="list-style-type: none"> 1. Adjust the table. 2. Replace the saw blade or put less pressure on the workpiece. |

TROUBLESHOOTING

LOWER WHEEL ADJUSTMENTS

The following instructions will correct common blade issues related to the lower wheel's alignment in relation to the upper wheel. These adjustments will correct the blade position on the lower wheel and blade oscillation (wobble). These are critical adjustments which affect the performance and accuracy of the bandsaw.

CAUTION PLEASE READ AND UNDERSTAND THESE STEPS THOROUGHLY BEFORE MAKING ANY ADJUSTMENTS. FAILURE TO DO SO COULD DAMAGE THE MACHINE.

Please contact a tech support representative if you have questions before attempting these adjustments.
RIKON Tech Support 877-884-5167 techsupport@rikontools.com

Release the blade tension completely before making any lower wheel adjustments. Pressure must be released on the lower wheel to allow proper adjustments and to avoid damaging the machine.

If the blade is not running true, or it is not running on center of the lower wheel but is correct on the upper wheel, then an adjustment to the wheel hub on the rear of the bandsaw is required.

The numbers 3, 6, 9, 12 shown on the rear hub photo represent the positions on a clock face for easy identification purposes.

NOTE: To help identify the extent of rotation on a bolt, mark a black dot on the edge of the bolt as a visual indicator.

If a blade is tracking forward on the lower wheel towards the door, follow these correction steps:

- 1.) De-tension the saw blade.
- 2.) Loosen 9 o'clock shaft bolt to take pressure off the shaft.
- 3.) Loosen 12 o'clock shaft bolt one half rotation.
- 4.) Tighten the 6 o'clock shaft bolt until the shaft touches the 12 o'clock adjusting bolt.
- 5.) Lock all three shaft bolts.
- 6.) Re-tension the saw blade and set the upper wheel to plumb by adjusting the tracking knob. Spin the upper wheel by hand and track the blade.
- 7.) Repeat if further adjustment is necessary.

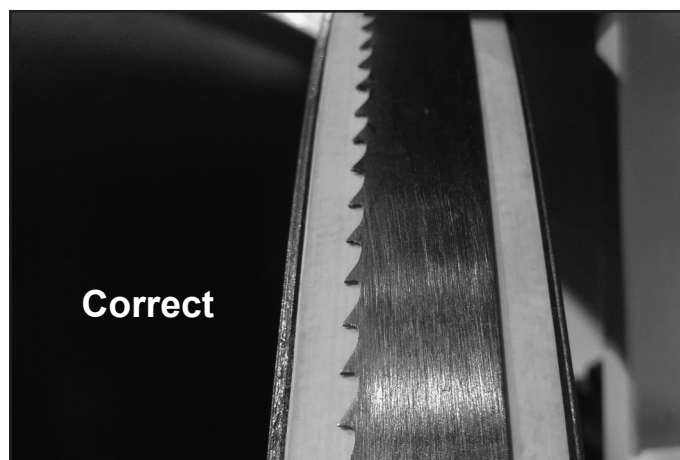
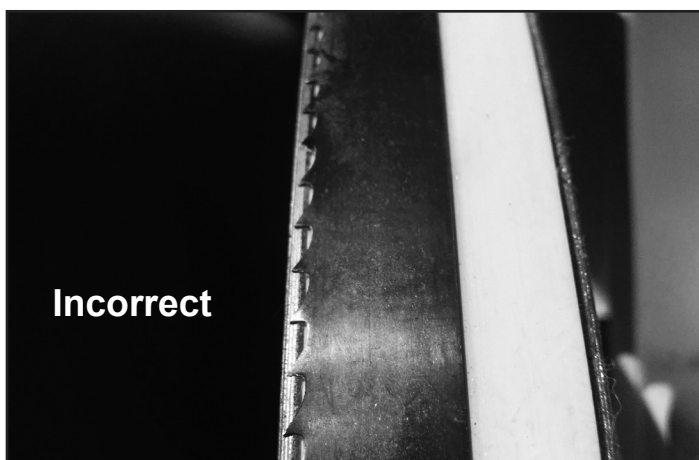

TROUBLESHOOTING

If a blade is tracking on the rear of the lower wheel, away from the door, follow these steps:

- 1.) De-tension the saw blade.
- 2.) Loosen 9 o'clock shaft bolt to take pressure off the shaft.
- 3.) Loosen 6 o'clock shaft bolt one half rotation.
- 4.) Tighten the 12 o'clock shaft bolt until the shaft touches the 6 o'clock adjusting bolt.
- 5.) Lock all three shaft bolts.
- 6.) Re-tension the saw blade and set the upper wheel to plumb by adjusting the tracking knob. Spin the upper wheel by hand and track the blade.
- 7.) Repeat if further adjustment is necessary.

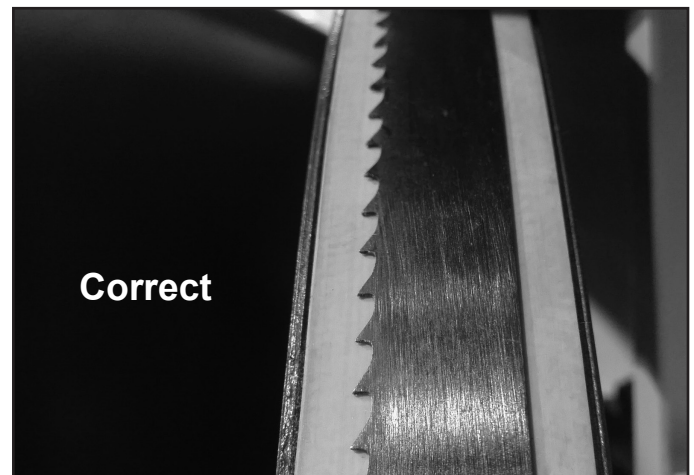
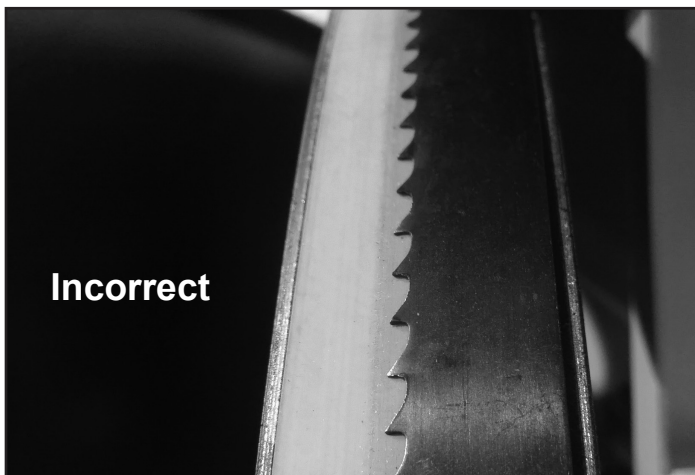

If a blade is moving back and forth (wobbling), follow these steps:

First, check the bandsaw blade to insure that it has been welded correctly, so that the blade's back is in proper alignment - flat (if it is laid down on a table surface).

If the blade is welded true, then adjustment to the wheel hub on the rear of the bandsaw is required.

- 1.) De-tension the saw blade.
- 2.) Loosen 6 o'clock shaft bolt to take pressure off of the shaft.
- 3.) Loosen 9 o'clock shaft bolt one half rotation.
- 4.) Tighten the 3 o'clock shaft bolt until the shaft touches the 9 o'clock adjusting bolt.
- 5.) Lock all three shaft bolts.
- 6.) Re-tension the saw blade and set the upper wheel to plumb by adjusting the tracking knob. Spin the upper wheel by hand and track the blade.
- 7.) Start the bandsaw and check blade movement.
- 8.) If movement has diminished then continue with the adjustment.
- 9.) If movement is worse, reverse the adjustments in steps 3 and 4.

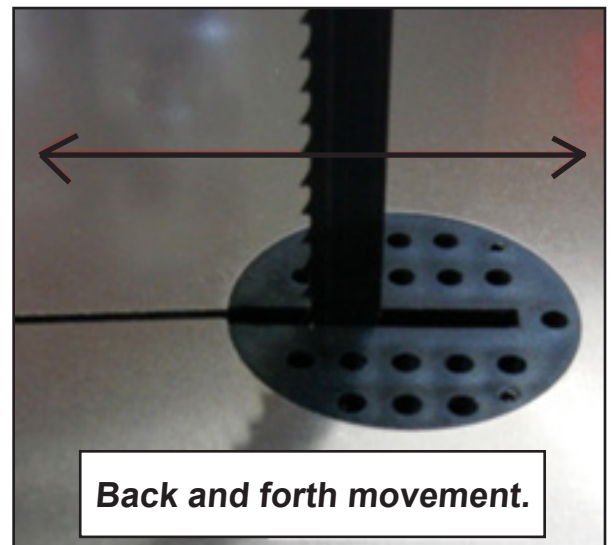

NOTE: 1/8" (3.18mm) blades should be 0.018" to 0.020" gauge to reduce tracking issues common with this width.

PARTS DIAGRAM

10-306 10" DELUXE BANDSAW

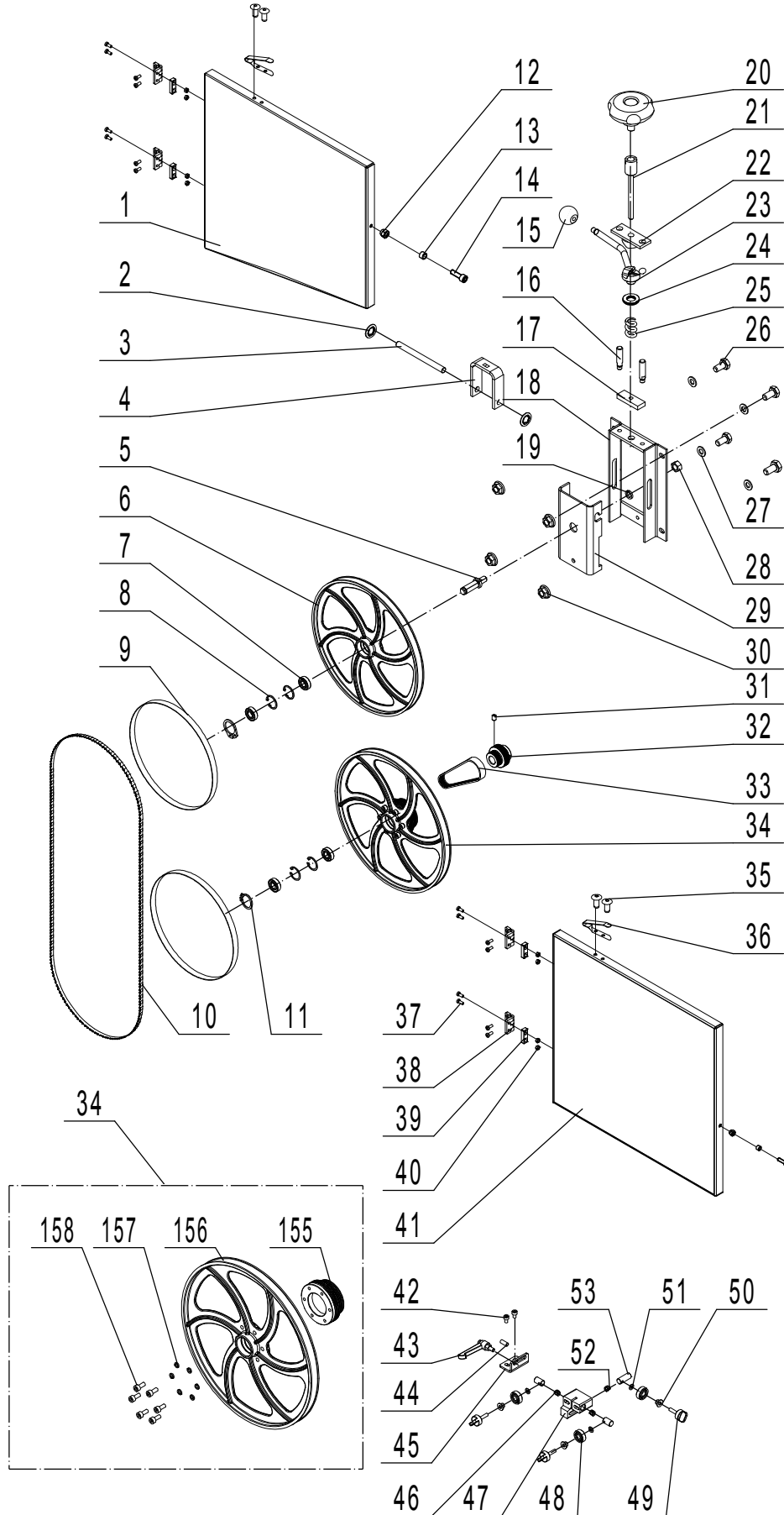

PARTS LIST

| KEY NO. | DESCRIPTION | QTY. | PART NO. |
|---------|--|------|-------------|
| 1 | Upper door assembly | 1 | P10-306-1 |
| 2 | Star lock washer | 2 | P10-306-2 |
| 3 | Mount shaft | 1 | P10-306-3 |
| 4 | Blade tensioner | 1 | P10-306-4 |
| 5 | Upper bearing bolt | 1 | P10-306-5 |
| 6 | Upper wheel | 1 | P10-306-6 |
| 7 | Bearing | 4 | P10-306-7 |
| 8 | Retaining ring 28 | 4 | P10-306-8 |
| 9 | Tire | 2 | P10-306-9 |
| 10 | Bandsaw blade | 1 | P10-306-10 |
| 11 | Retaining ring 12 | 2 | P10-306-11 |
| 12 | Hex lock nut M6 | 2 | P10-306-12 |
| 13 | Bushing | 2 | P10-306-13 |
| 14 | Hex socket head cap screw M6X25 | 2 | P10-306-14 |
| 15 | Handle end knob | 1 | P10-306-15 |
| 16 | Pilot pin | 2 | P10-306-16 |
| 17 | Connecting plate | 1 | P10-306-17 |
| 18 | Tension bracket assembly | 1 | P10-306-18 |
| 19 | Spring washer | 1 | P10-306-19 |
| 20 | Tension handle | 1 | P10-306-20 |
| 21 | Tension rod assembly | 1 | P10-306-21 |
| 22 | Upper cam wheel | 1 | P10-306-22 |
| 23 | Quick release lever with cam wheel | 1 | P10-306-23 |
| 24 | Axial needle and cage assembly | 1 | P10-306-24 |
| 25 | Pressure spring | 1 | P10-306-25 |
| 26 | Hex bolt | 4 | P10-306-26 |
| 27 | Flat washer | 4 | P10-306-27 |
| 28 | Hex nut M10 | 1 | P10-306-28 |
| 29 | Connecting plate | 1 | P10-306-29 |
| 30 | Flange nut | 4 | P10-306-30 |
| 31 | Hex socket set screw M6X10 | 1 | P10-306-31 |
| 32 | Motor belt pulley | 1 | P10-306-32 |
| 33 | Poly V-belt | 1 | P10-306-33 |
| 34 | Lower wheel assembly (see #155-158) | 1 | P10-306-34 |
| 35 | Self-plugging rivet | 4 | P10-306-35 |
| 36 | Leaf spring | 2 | P10-306-36 |
| 37 | Cross recess pan head screw M4X10 | 16 | P10-306-37 |
| 38 | Hinge assembly | 4 | P10-306-38 |
| 39 | Thread plate | 4 | P10-306-39 |
| 40 | Hex nut M4 | 8 | P10-306-40 |
| 41 | Lower door assembly | 1 | P10-306-41 |
| 42 | Cylinder head hex socket bolts M5X8 | 2 | P10-306-42 |
| 43 | Ratchet handle | 1 | P10-306-43 |
| 44 | Hex socket set screw with flat point M6X12 | 1 | P10-306-44 |
| 45 | Connecting plate | 1 | P10-306-45 |
| 46 | Spring 0.5 | 4 | P10-306-46 |
| 47 | Lower guide assembly | 1 | P10-306-47 |
| 48 | Bearing | 6 | P10-306-48 |
| 49 | Locking handle | 5 | P10-306-49 |
| 50 | Bearing bushing | 6 | P10-306-50 |
| 51 | Flat washer | 6 | P10-306-51 |
| 52 | Spring 0.5 | 2 | P10-306-52 |
| 53 | Adjusting spindle | 1 | P10-306-53 |
| 155 | Lower wheel belt pulley | 1 | P10-306-155 |
| 156 | Lower wheel | 1 | P10-306-156 |
| 157 | Spring washer | 4 | P10-306-157 |
| 158 | Screw M5X12 | 4 | P10-306-158 |

NOTE: Please reference the Part Number when calling for Replacement Parts.
 For Parts under Warranty, the serial number of your machine is required.

PARTS DIAGRAM

10-306 10" DELUXE BANDSAW

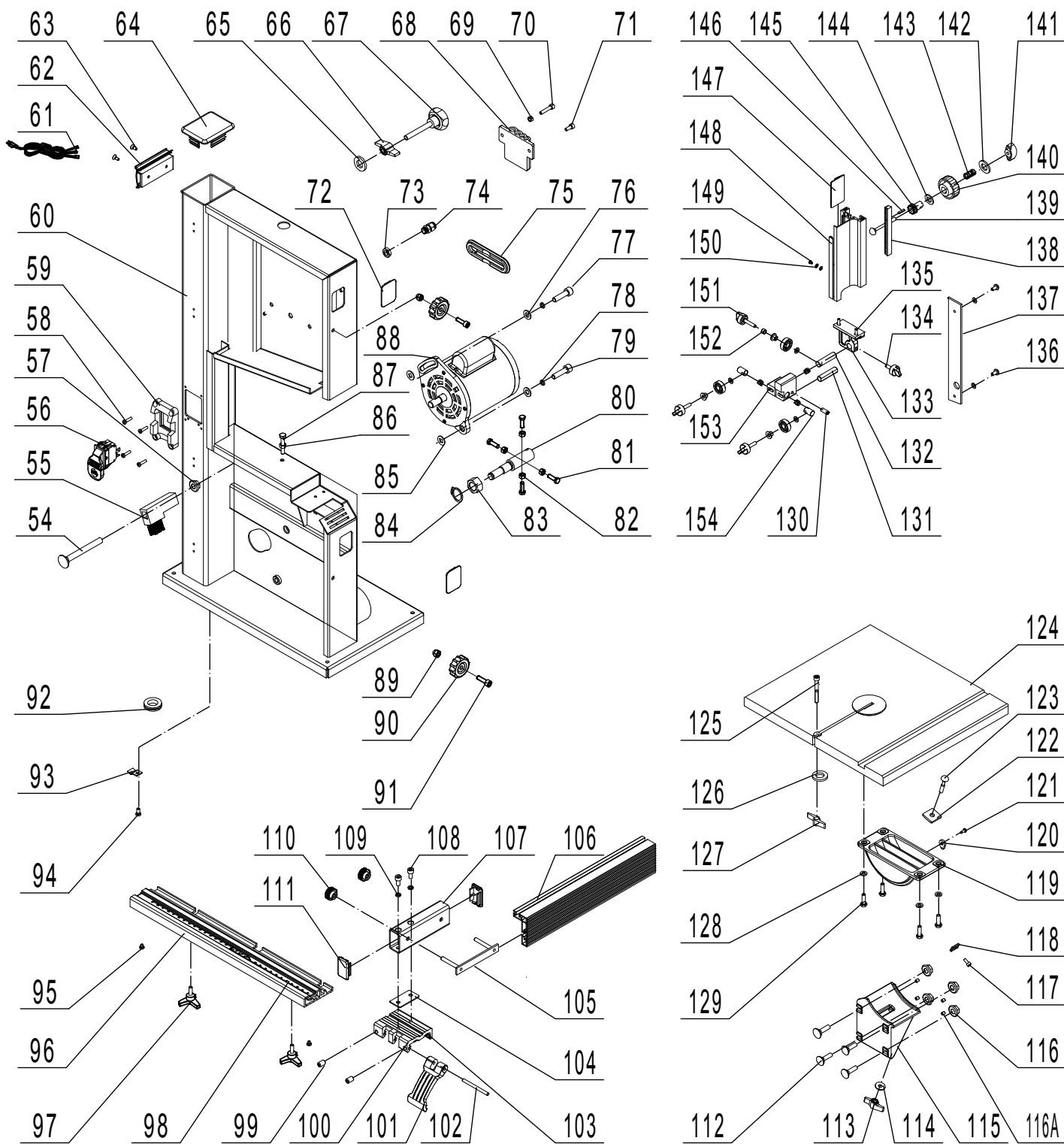

NOTE: Please reference the Part Number when calling for Replacement Parts.
For Parts under Warranty, the serial number of your machine is required.

PARTS LIST

| KEY NO. | DESCRIPTION | QTY. | PART NO. | KEY NO. | DESCRIPTION | QTY. | PART NO. |
|---------|----------------------------|------|-------------|---------|------------------------------|------|--------------|
| 54 | Square neck bolt | 1 | P10-306-54 | 105 | Locking frame bar | 1 | P10-306-105 |
| 55 | Brush | 1 | P10-306-55 | 106 | Fence | 1 | P10-306-106 |
| 56 | Key switch | 1 | P10-306-56 | 107 | Fence carrier block | 1 | P10-306-107 |
| 57 | Hex nut with flange M8 | 1 | P10-306-57 | 108 | Hex socket cap screw M6X12 | 2 | P10-306-108 |
| 58 | Pan head screw M4X16 | 4 | P10-306-58 | 109 | Spring washer | 2 | P10-306-109 |
| 59 | Switch panel | 1 | P10-306-59 | 110 | Knob | 2 | P10-306-110 |
| 60 | Frame | 1 | P10-306-60 | 111 | End cap | 2 | P10-306-111 |
| 61 | Power plug | 1 | P10-306-61 | 112 | Square neck bolt M6X16 | 4 | P10-306-112 |
| 62 | Fence hanging panel | 1 | P10-306-62 | 113 | Wing nut | 1 | P10-306-113 |
| 63 | Countersunk screw M4X10 | 2 | P10-306-63 | 114 | Flat washer | 1 | P10-306-114 |
| 64 | Column top cap | 1 | P10-306-64 | 115 | Support | 1 | P10-306-115 |
| 65 | Washer | 1 | P10-306-65 | 116 | Flange nut | 4 | P10-306-116 |
| 66 | Wing nut | 1 | P10-306-66 | 116A | Set screw M5X6 | 4 | P10-306-116A |
| 67 | Handle bar | 1 | P10-306-67 | 117 | Hex socket cap screw M4X10 | 1 | P10-306-117 |
| 68 | Tool holder | 1 | P10-306-68 | 118 | 45° table tilt stop block | 1 | P10-306-118 |
| 69 | Hex nut M5 | 1 | P10-306-69 | 119 | Upper table trunnion | 1 | P10-306-119 |
| 70 | Hex socket cap screw M5X25 | 1 | P10-306-70 | 120 | Angle indicator | 1 | P10-306-120 |
| 71 | Hex socket cap screw M5X12 | 1 | P10-306-71 | 121 | Tapping screw | 1 | P10-306-121 |
| 72 | Window | 2 | P10-306-72 | 122 | Sliding block | 1 | P10-306-122 |
| 73 | Strain relief nut | 1 | P10-306-73 | 123 | Square neck bolt M6X35 | 1 | P10-306-123 |
| 74 | Strain relief | 1 | P10-306-74 | 124 | Table assembly | 1 | P10-306-124 |
| 75 | Dust cover | 1 | P10-306-75 | 125 | Hex socket cap screw M6X30 | 1 | P10-306-125 |
| 76 | Flat washer | 2 | P10-306-76 | 126 | Flat washer | 1 | P10-306-126 |
| 77 | Screw M8X30 | 1 | P10-306-77 | 127 | Wing nut | 1 | P10-306-127 |
| 78 | Spring washer | 2 | P10-306-78 | 128 | Washer | 4 | P10-306-128 |
| 79 | Screw M8X30 | 1 | P10-306-79 | 129 | Hex bolt M6X12 | 4 | P10-306-129 |
| 80 | Lower wheel shaft | 1 | P10-306-80 | 130 | Hex screw w/ cup point M6X16 | 1 | P10-306-130 |
| 81 | Hex bolt M6X20 | 4 | P10-306-81 | 131 | Support shaft | 1 | P10-306-131 |
| 82 | Hex nut M6 | 4 | P10-306-82 | 132 | Front adjust shaft | 1 | P10-306-132 |
| 83 | Nut M14 | 1 | P10-306-83 | 133 | Back-up block | 1 | P10-306-133 |
| 84 | Circlip for shaft | 1 | P10-306-84 | 134 | Clamp handle | 1 | P10-306-134 |
| 85 | Washer | 2 | P10-306-85 | 135 | Screw M4X16 | 2 | P10-306-135 |
| 86 | Hex nut M6 | 1 | P10-306-86 | 136 | Screw M5X10 | 2 | P10-306-136 |
| 87 | Hex bolt M6X35 | 1 | P10-306-87 | 137 | Locking plate | 1 | P10-306-137 |
| 88 | Motor | 1 | P10-306-88 | 138 | Rack | 1 | P10-306-138 |
| 89 | Hex locking nut M6 | 2 | P10-306-89 | 139 | Square neck bolt M6X50 | 1 | P10-306-139 |
| 90 | Door locking knob | 2 | P10-306-90 | 140 | Blade guide lifting handle | 1 | P10-306-140 |
| 91 | Hex socket cap screw M6X20 | 2 | P10-306-91 | 141 | Clamp handle | 1 | P10-306-141 |
| 92 | Rubber bushing | 1 | P10-306-92 | 142 | Washer | 1 | P10-306-142 |
| 93 | Cable pressing plate | 1 | P10-306-93 | 143 | Spring | 1 | P10-306-143 |
| 94 | Pan head screw M5X10 | 1 | P10-306-94 | 144 | Adjustable pad | 1 | P10-306-144 |
| 95 | Pan head screw M4X5 | 2 | P10-306-95 | 145 | Wheel gear | 1 | P10-306-145 |
| 96 | Guide rail | 1 | P10-306-96 | 146 | Roll pin | 1 | P10-306-146 |
| 97 | Star knob screw | 2 | P10-306-97 | 147 | Sliding plate | 1 | P10-306-147 |
| 98 | Scale | 1 | P10-306-98 | 148 | Blade guide | 1 | P10-306-148 |
| 99 | Plastic screw | 2 | P10-306-99 | 149 | Pan head screw M3X4 | 1 | P10-306-149 |
| 100 | Fence carrier | 1 | P10-306-100 | 150 | Flat washer | 2 | P10-306-150 |
| 101 | Eccentric lever handle | 1 | P10-306-101 | 151 | Clamp handle | 1 | P10-306-151 |
| 102 | Mandrel | 1 | P10-306-102 | 152 | Cover | 1 | P10-306-152 |
| 103 | Plastic spacer | 6 | P10-306-103 | 153 | Upper blade guide assy | 1 | P10-306-153 |
| 104 | Spacer | 1 | P10-306-104 | 154 | Rear guide adjust shaft | 4 | P10-306-154 |

ACCESSORIES



13-913 10" BANDSAW STAND

Made of all steel components with black enamel finish and includes rubber non-slip foot pads. Top open frame measures 14-1/2" x 9-3/4" with 4 pre-formed slots for directly mounting machines or a plywood top for supporting and attaching machines with bases that do not match the slot locations. Base is 25" x 18-3/4", and the stand is 25" high.



13-920 MITER GAUGE

Fits 5/8" x 3/8" miter slots. Aluminum body with 60° scale for left and right angle settings. Includes pre-drilled holes in face for attaching your own wooden faces or extensions (not included), a push handle, and extra bar for use on machines with or without 'T' slots.



BAND SAW BLADES

Made of carbon-rich steel, hardened and tempered with razor sharp teeth for superior cutting and chip evacuation. For a complete line of 70-1/2" band saw blades, contact your local RIKON Distributor, or visit the RIKON website at www.rikontools.com.



C10-393 TABLE INSERTS - Pack of 4

Replacement plastic inserts with central slots for positioning the bandsaw blade. Inserts provide solid support of projects during cutting.



C10-109 GUIDE BEARINGS - Pack of 6

Replacement radial, deep groove ball bearings are pre-lubricated with two rubber seals for smooth operation and long service as blade guides.



C10-394 ZERO CLEARANCE INSERTS - Pack of 4

Solid plastic inserts have no slot and require user to cut their own on installation. This minimizes the slot width so debris or thin cut wood strips will not catch or fall into the thin slot. Ideal for use when cutting small pieces on the bandsaw for inlay, shims, puzzles, etc.

How-To's for all Band Saw Blades

Choosing the Correct Blade Width

Blade width is measured from the tips of the teeth to the back edge of the blade as shown above. The instructions for the particular machine being used should be followed when selecting blade width.



If no such instructions are provided, blade width should be determined with the following guidelines:

For Cut-Off Sawing, the blade should be as wide as the machine will allow. The wider the band is, the straighter the cut will be. Faster feeding can be achieved.

For Contour Sawing, the blade should be as wide as the machine allows, but still narrow enough so that it can cut the desired shape (radius). Minimum dimensions for different cutting radii are shown on the chart at right.

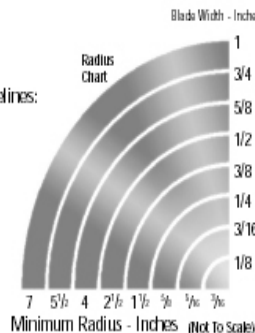

How To Choose The Correct Number Of Teeth Per Inch (TPI)

The number of teeth per inch (TPI) is important in obtaining the finish desired and the proper feed rate. A coarse tooth blade (2, 3 TPI) should be used for resawing wood and cutting thicker stock up to 8". A fine toothed blade (18 to 32 TPI) should be used for thinner metals and plastics under 1/4". For general cutting of 3/4" wood 4 TPI will provide a fast cut and 14 TPI will cut slow, but leave a smoother finish.

When Selecting TPI remember:

- More TPI give a smoother but slower cut
- Fewer TPI allow a faster cut with a slightly rougher finish
- At least three teeth must be in the workpiece—the chart to the right will help you decide.

| TPI | Minimum Material Thickness |
|-----|----------------------------|
| 32 | 3/32" |
| 24 | 1/8" |
| 18 | 5/32" |
| 14 | 1/4" |
| 10 | 5/16" |
| 8 | 3/8" |
| 6 | 1/2" |
| 4 | 3/4" |
| 3 | 1" |
| 2 | 1-1/2" |

It is important to know the SFM for the various speed settings of your band saw, so that you can select the proper speed for cutting wood or other materials. Check the operator's manual of your band saw to determine the SFM or use the following procedure:

1. Determine the RPM: check the operator's manual or clock the revolutions per minute of the wheels with a tachometer or revolution counter.
2. Measure the diameter of the drive wheel in inches and multiply by .262 to obtain the wheel circumference. The RPM times circumference equals the surface speed of the blade.
RPM x diameter in inches x .262 = SFM.

Note: Spring Steel Wood Cutting Band Saw Blades should never be operated at surface speeds above 3000 SFM. Carbon Hard Edge Flexible Back Band Saw Blades may be run up to 8000 SFM.

Installing your Band Saw Blade

1. Unplug the saw, then loosen the tension on the upper wheel. With all the blade guides backed off, slip the new blade around the wheels and then tension it.
2. When you have tensioned the blade enough to keep it on the wheels, track it by turning the upper wheel with one hand while adjusting the tilt of the wheel's axis with the other hand. The blade should ride in the middle of the rim. **Never track the blade with the motor running and the cover open.**
3. Next, adjust the blade guides; first the thrust bearings: upper and lower, then the left hand side guides.
4. Use a square to make sure you are not pushing the blade out of line and place a piece of white paper between the blade guide and the blade to allow for clearance.

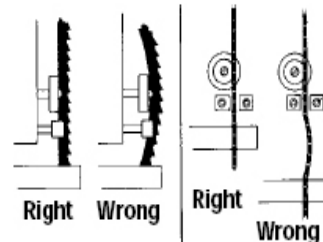

Diagnosing Problems

1. Premature and Excessive Tooth Wear

- Feed pressure too light, increase it.
- Lower band velocity.
- Improper tooth selection, use a finer pitch.
- Improper break-in with new band. Velocity and feeding should be reduced the first few cuts.
- Teeth are running the wrong direction.
- Be sure teeth are pointing in proper direction.
- Incorrect saw guide insert size for the band, allowing them to strike teeth

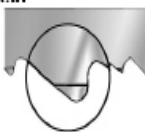

2. Blade Vibration

- Increase or decrease band velocity.
- Teeth too coarse for workpiece.
- Material not securely held.
- Increase tension of band.
- Increase feed pressure.

3. Gullets Loading

- Teeth too fine for workpiece - use a coarser pitch.
- Decrease band velocity.

4. Band Stalls in Work

- Feed pressure too great - decrease feed.
- Teeth too coarse, use finer tooth blade

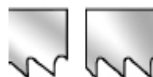

5. Premature Blade Breakage

- Thickness of blade too heavy for diameter of wheels and speed of machine
- Increase or decrease velocity
- Check wheels for defects
- Teeth too coarse for workpiece - use a finer pitch
- Decrease blade tension - Decrease feeding force
- Brittle weld - increase annealing period, decreasing heat gradually
- Check for proper adjustment of band guides, saw guides, saw guide inserts and back-up bearings.

6. Blade Making Belly-Shaped Cuts

- Increase tension.
- Adjust guides closer to workpiece.
- Teeth too fine - use a coarse pitch.
- Decrease feed force.
- Teeth dull.



7. Tooth Stripping

- Teeth too coarse for workpiece.
- Material not securely held.
- Too much feed pressure - reduce for good chip curl.
- Band velocity too low - increase speed.

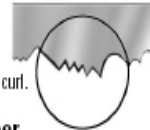

8. Band Develops a Negative Camber

- Band is riding on saw guide backup bearing too heavily. Adjust band for alignment on top and bottom wheels.
- Check band wheel alignment.



9. Blade Not Running True Against Saw Guide Backup Bearing

- If clicking noise against saw guide backup bearing, remove burr on band.
- Check band wheel alignment.
- Check saw guide backup bearing for wear, replace if necessary
- Weld not in proper alignment. Reweld blade straight and true.

10. Cutting Rate Too Slow

- Increase band velocity.
- Increase feed pressure.
- Use a coarser pitch.



11. Blade Leading In Cut

- Reduce feed pressure or rate.
- Check adjustments and wear of saw guides or rollers.
- Lack of band tension.
- Tooth set damage.

12. Premature Loss of Set

- Improper width selection - check chart for correct width for radius cutting.
- Reduce band velocity.

13. Band Develops Positive Camber

- Decrease force.
- Use a coarser pitch to increase tooth penetration.
- Adjust saw guides closer to work.



14. Band Develops Twist

- Wrong width for radius being cut - choose a narrower blade.
- Binding in cut - decrease feed pressure.
- Decrease band tension.
- Adjust saw guides further from workpiece.



15. Finished Cut Surface Too Rough

- Improper tooth selection - choose a finer pitch.
- Increase band velocity.
- Decrease feed rate.



16. Band Scoring (side wear or grooving)

- Check for wear on saw guide inserts.
- Too much pressure on saw guide inserts.
- Check alignment of saw guides - be sure they are square to front vise. Replace or clean guides.



17. Burring or Mushrooming of Blade Back Edge

- Increase tension and adjust guides.
- Check contact between blade and back edge rollers.
- Reduce feed pressure.
- Use coarser pitch blade.
- Use finishing stone.



WARRANTY

RIKON

POWER TOOLS®

5-Year Limited Warranty

RIKON Power Tools Inc. ("Seller") warrants to only the original retail consumer/purchaser of our products that each product be free from defects in materials and workmanship for a period of five (5) years from the date the product was purchased at retail. This warranty may not be transferred.

This warranty does not apply to defects due directly or indirectly to misuse, abuse, negligence, accidents, repairs, alterations, lack of maintenance or normal wear and tear. Under no circumstances will Seller be liable for incidental or consequential damages resulting from defective products. All other warranties, expressed or implied, whether of merchantability, fitness for purpose, or otherwise are expressly disclaimed by Seller. This five-year warranty does not cover products used for commercial, industrial or educational purposes. The warranty term for these claims will be limited to a two-year period.

This limited warranty does not apply to accessory items such as blades, drill bits, sanding discs, grinding wheels, belts, guide bearings and other related items.

Seller shall in no event be liable for death, injuries to persons or property, or for incidental, contingent, special, or consequential damages arising from the use of our products.

To take advantage of this warranty, proof of purchase documentation must be provided which has the date of purchase and an explanation of the complaint.

The Seller reserves the right to effect at any time, without prior notice, those alterations to parts, fittings, and accessory equipment which they may deem necessary for any reason whatsoever.

To register your machine online, visit RIKON at www.rikontools.com/warranty

**To take advantage of this warranty, or if you have any questions,
please contact us at 877-884-5167 or email warranty@rikontools.com**

The RIKON website has information regarding your machine, its accessories, the full line of other RIKON machines, accessories, and a listing of authorized RIKON Distributors in your area.





**For more information:
16 Progress Road
Billerica, MA 01821**

**877-884-5167 / 978-528-5380
techsupport@rikontools.com**

