

ZT X™ ZT XL™



Operator's Manual Manuel du Utilisateur

GRAVELLY.

Models

915172 – ZT X 42
(SN 020000 +)

915174 – ZT X 52
(SN 020000 +)

915176 – ZT X 42 CARB
(SN 020000 +)

915200 – ZT XL 52
(SN 020000 +)

915202 – ZT XL 42
(SN 020000 +)

915204 – ZT XL 52
(SN 020000 +)

915206 – ZT XL 42
(SN 020000 +)

915216 – ZT XL 60
(SN 020000 +)

915218 – ZT XL 60
(SN 020000 +)

915230 – ZT X 52
(SN 020000 +)

915236 – ZT X 52 CARB
(SN 020000 +)

915238 – ZT XL 42 CARB
(SN 020000 +)

915240 – ZT XL 52 CARB
(SN 020000 +)

915242 – ZT XL 60 CARB
(SN 020000 +)

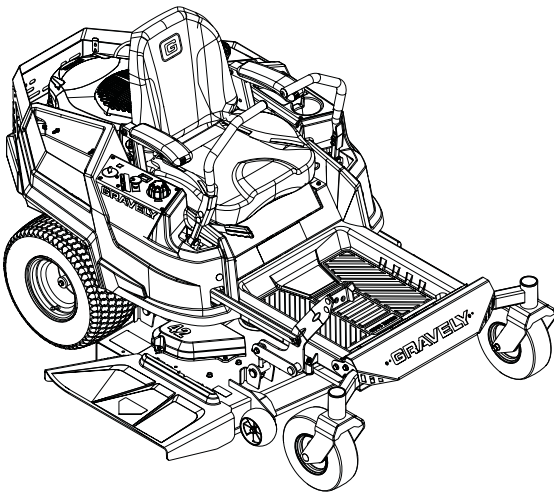

EN ENGLISH

FR FRANÇAIS

05102200C • 2/17

Printed in USA

TABLE OF CONTENTS

WELCOME	1	Adjust Seat	28
SAFETY	2	Adjust Steering Levers	28
Practices & Laws	2	Adjust Unit to Track Straight	29
Emission Control System	2	Adjust Parking Brake Lever	30
Required Operator Training	2	Remove and Install Mower Deck	30
Safety Alert Symbol	2	Adjust Mower Deck	32
Signal Words	2	TROUBLESHOOTING	34
Safety Decals	3	STORAGE	36
Safety Rules	6	Short-Term Storage	36
CONTROLS AND FEATURES	11	Long-Term Storage	36
Ignition Key	12	Start-of-Season Preparation	36
Choke Control Knob	12	ACCESSORIES	36
Throttle Control Lever	12	SPECIFICATIONS	37
Power-Take-Off (PTO) Knob	12	WARRANTY	41
Hour Meter	12		
Height-of-Cut Dial	12		
Deck Lift Pedal	12		
Seat Adjustment Lever	12		
Parking Brake Lever	13		
Safety Interlock System	13		
Steering Levers	13		
Transaxle Bypass Levers	13		
Anti-scalp Rollers	13		
OPERATION	13		
Emergency Stopping	13		
Before Operating Unit	13		
Start the Engine	14		
Operate Unit	14		
Stop the Engine	15		
Move Unit Manually	15		
Transport Unit	16		
MAINTENANCE	16		
Maintenance Schedule	16		
Service Parts	16		
Service Position	20		
Check Safety Interlock System	20		
Check Parking Brake	20		
Check Engine Oil	20		
Check Tire Pressure	21		
Check Carbon Canister Filter	21		
Check Fasteners	21		
Lubricate Unit	21		
Check Mower Blades	22		
Check Battery	23		
Check Mower Belts	24		
Hydraulic Oil	27		
ADJUSTMENTS	28		

WELCOME

Congratulations on your purchase and welcome to the Gravelly family! Every machine in the Gravelly lineup is designed for long-lasting and unsurpassed performance. We are confident your machine will be part of your family for many years to come.

Have Questions or Need Assistance?
gravelly.custhelp.com • gravellymower.com

A parts manual for your unit is available for free download
or purchase at gravelly.com.

Manual del operador español está disponible para su descarga gratuita o
compra en gravelly.com.

PRODUCT REGISTRATION

You or the dealer you purchased the unit from must register the product at the time of purchase. Know the model and serial numbers of your unit and register online at gravelly.com or return the registration card to Ariens Company. See Figure 1 for label location.

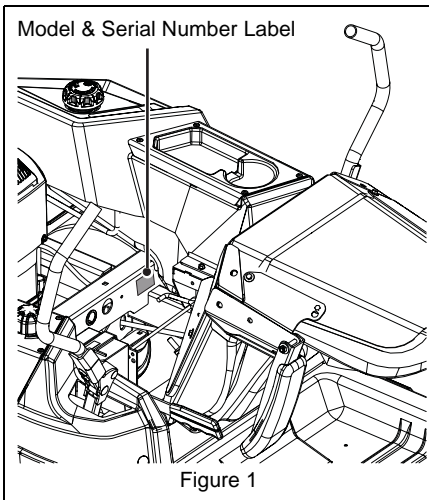

Record model number here.

Record serial number here.

MANUALS

Before operating or servicing the unit, carefully and completely read the manuals provided with the unit. They contain safety instructions and important information about unit controls.

The engine on this unit is covered by a separate manual. Refer to the engine manual for engine service recommendations. Contact the engine manufacturer for a replacement manual if necessary.

It is your responsibility to read and understand all safety precautions and instructions in the manuals. If you do not understand or have difficulty following the instructions, contact your Gravelly dealer for assistance. To locate your nearest dealer, go to gravellymower.com.

DISCLAIMER

Gravelly reserves the right to discontinue, make changes to, and add improvements upon its products at any time without public notice or obligation. The descriptions and specifications contained in this manual were in effect at printing. Equipment described in this manual may be optional. Some illustrations may not be applicable to your unit.

SAFETY

Read these safety rules and follow them closely. Failure to follow these rules could lead to loss of control of unit, severe personal injury or death to you or bystanders, or result in damage to property or the machine.

PRACTICES & LAWS

Practice usual and customary safe working precautions. Learn applicable rules and laws in your area. Always follow the practices set forth in this manual.

EMISSION CONTROL SYSTEM

This equipment and/or its engine may include exhaust and evaporative emissions control system components required to meet U.S. Environmental Protection Agency (EPA) and/or California Air Resources Board (CARB) regulations. Tampering with emission controls and components by unauthorized personnel may result in severe fines or penalties. Emission controls and components can only be adjusted by an Ariens Company dealer or an authorized engine manufacturer's service center. Contact your Ariens Company Equipment Retailer concerning emission controls and component questions.

REQUIRED OPERATOR TRAINING



Read and understand the Operator's Manual and decals on the unit. This information is for your safety and the proper use of your equipment. Failure to follow these

instructions and warnings may cause death or serious injury. If you have purchased this product from a Gravely dealer, the dealer can provide you with training.

Familiarize yourself and any other operators with all controls and the safe use of the features of this unit. If you loan, rent or sell this product to others, provide them with all manuals.

If you have any questions, please call our customer support line at 920-756-4688 or contact us at www.gravely.com. Do not use this equipment if, after reading the Operator's Manual and the on-board decals, you have any questions about the safe use of this product.



WARNING: AVOID INJURY. This cutting machine is capable of amputating hands and feet and throwing objects. Failure to observe the safety instructions in the manuals and on decals could result in serious injury or death.

SAFETY ALERT SYMBOL



This is the safety alert symbol. It means:

- **ATTENTION!**
- **YOUR SAFETY IS INVOLVED!**

When you see this symbol:

- **BECOME ALERT!**
- **OBEY THE MESSAGE!**

SIGNAL WORDS

The safety alert symbol above and signal words below are used on decals and in this manual. Read and understand all safety messages.

1. Danger



DANGER: Indicates an **IMMINENTLY HAZARDOUS SITUATION!** If not avoided, **WILL RESULT** in death or serious injury.

2. Warning



WARNING: Indicates a **POTENTIALLY HAZARDOUS SITUATION!** If not avoided, **COULD RESULT** in death or serious injury.

3. Caution



CAUTION: Indicates a **POTENTIALLY HAZARDOUS SITUATION!** If not avoided, **MAY RESULT** in minor or moderate injury. It may also be used to alert against unsafe practices.

4. Notice

NOTICE: Indicates information or procedures that are considered important but not hazard related. If not avoided property damage could result.

5. Important

IMPORTANT: Indicates general reference information worthy of special attention.

SAFETY DECALS

The safety decals on your machine are visual reminders of the important safety information in this manual. All messages on your unit must be fully understood and carefully followed. Safety decals on the machine are explained below.



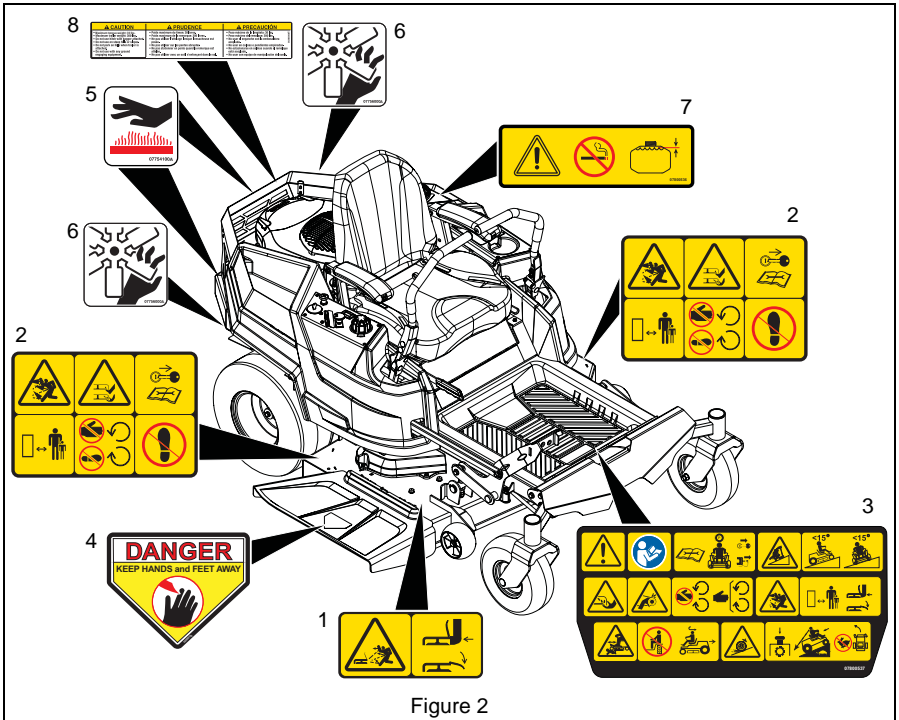

Safety Decal Locations



ALWAYS replace missing or damaged safety decals. Replacement decal part numbers are found in the parts manual for your machine and may be ordered from your dealer.

See Figure 2 for safety decal locations.

Safety Decal Descriptions

<p>1. DANGER!</p>  <p>Discharge Hazard - NEVER operate unit without discharge chute in operating position. Thrown objects can cause injury or damage.</p>  <p>DO NOT operate mower unless all guards are in operating position or bagger is attached.</p>	<p>2. DANGER!</p>  <p>Discharge Hazard - NEVER direct discharge toward people, pets or property. Thrown objects can cause injury or damage.</p>  <p>Amputation Hazard - NEVER stick hands or feet under deck or shielded areas.</p>
--	--



Shut off engine, remove key, and read manual before servicing or making adjustments to unit.



Keep children and others away from unit while unit is in operation.



Keep feet and hands away from all rotating or moving parts.



DO NOT step or stand in this area.

3. DANGER!



DANGER!



Read and understand the operator's manual before operating unit.

3.1 Amputation Hazard



To avoid amputation hazard DO NOT put hands near rotating blades.



To avoid amputation hazard DO NOT put hands near moving belts.



Keep hands away from all rotating or moving parts.

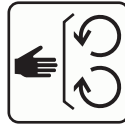

Keep all guards and shields in place.

3.2 Discharge Hazard



Discharge Hazard - NEVER direct discharge toward people, pets or property. Thrown objects can cause injury or damage.

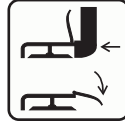

DO NOT operate mower unless all guards are in operating position or bagger is attached.

3.3 Tipping Hazard



Avoid tipping hazard.



DO NOT operate on slopes over 15° .



DO NOT operate on slopes over 15° .

3.4 Service Hazard



Before servicing unit do the following:



Read owners manual before servicing or making adjustments to unit.



Set parking brake.



Remove key and disconnect spark plug before servicing or making adjustments to unit.

3.5 Bystander Hazard



DO NOT operate the unit in the presence of bystanders.



DO NOT carry passengers.



Look behind when operating the unit in reverse.

3.6 Loss of Traction Hazard



If loss of traction is experienced do the following:

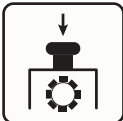

Disengage PTO.



Proceed off slope slowly.



DO NOT try to turn or speed up.

4. DANGER!



ALWAYS keep hands and feet away from discharge chute.

5. HOT PARTS!



DO NOT touch parts which are hot from operation. ALWAYS allow parts to cool.

6. ROTATING PARTS!



AVOID INJURY. Stay clear of rotating parts.

7. DANGER!



DANGER!



No smoking.

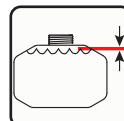

IMPORTANT: DO NOT overfill. Fill fuel tank to below bottom of filler neck.

WARNING: Overfilling may cause severe damage to evaporative system!

- NEVER fill fuel tank when engine is running, hot or unit is indoors. NEVER overfill fuel tank.
- Replace fuel cap securely and clean up spilled fuel.

8. CAUTION!



- Maximum tongue weight: 30 lbs.
- Maximum trailer weight: 300 lbs.
- Do not use hitch with bagger attached.
- Do not use on steep hills or slopes.
- Do not park on hills when trailer is attached.
- Do not use with any ground engaging equipment.

SAFETY RULES

The following safety instructions are based on the B71.1 specifications of the American National Standards Institute and ISO 5395 in effect at the time of production.

Training

Read, understand, and follow all instructions on the machine and in the manual(s) before starting.

Be sure the area is clear of bystanders and pets before operating. Stop machine if anyone enters the area.

Improper use of power equipment can cause serious permanent injury or death to the operator or a bystander.

Understand:

- How to operate all controls
- The functions of all controls
- How to STOP in an emergency
- Braking and steering characteristics
- Turning radius and clearances

If the operator or the mechanic cannot read the manual, it is the owner's responsibility to explain it to them.

ALWAYS train any inexperienced operators and require them to read and understand all manuals and decals.

Only allow responsible adults, who are familiar with the instructions, to operate this machine.

Only the operator can prevent and is responsible for accidents or injuries occurring to themselves, other people or property.

Operator Age

DO NOT allow children under the age of 18 to operate any outdoor power equipment.

Local regulations may restrict the age of the operator.

Data indicates operators age 60 years and above are involved in a large percentage of riding mower-related injuries.

These operators should evaluate their ability to operate the riding mower safely enough to protect themselves and others from serious injury.

Children

Tragic accidents can occur if the operator is not alert to the presence of children. Children are often attracted to the machine and the mowing activity. NEVER assume that children will remain where you last saw them.

Be alert and turn machine off if a child enters the area.

Before and while backing, look behind and down for small children.

NEVER carry children, even with the blade(s) shut off. They may fall off and be seriously injured or interfere with safe machine operation. Children who have been given rides in the past may suddenly appear in the mowing area for another ride and be run over or backed over by the machine.

NEVER allow children to operate the machine.

Use extreme care when approaching blind corners, shrubs, trees or other objects that may block your view of a child.

Keep children out of the mowing area and in the watchful care of a responsible adult other than the operator.

Personal Protection

DO NOT wear loose clothing or jewelry and tie back hair that may get caught in rotating parts.

Wear adequate outer garments.

NEVER wear open sandals or canvas shoes during operation. Wear adequate safety gear, protective gloves and footwear.

Wear proper footwear to improve footing on slippery surfaces.

ALWAYS wear eye and ear protection when operating machine.

Before Operating
Keep all nuts and bolts tight to be sure the equipment is in safe working condition.
Maintain the machine to be in compliance with the maintenance schedule.
Clean grass and debris from unit, especially from around muffler and engine, to help prevent fires.
Check parking brake operation frequently. Adjust and service as required.
Inspect unit before each use for missing or damaged decals and shields, correctly operating safety interlock system, and deterioration of grass catchers. Replace or repair as needed.
Ensure Safety Interlock System is functioning properly. DO NOT operate unit if safety interlock is damaged or disabled.
Start and operate unit only when seated in operator's position. Steering control levers must be in neutral, PTO disengaged and parking brake set when starting engine.
NEVER interfere with the intended function of a safety device or reduce the protection provided by a safety device. Check their proper operation regularly.
Keep machine free of grass, leaves or other debris build-up. Clean up oil or fuel spillage and remove any fuel-soaked debris.

Operation
Be sure the area is clear of bystanders before operating. Stop machine if anyone enters the area.
NEVER operate machine in a closed or poorly-ventilated area.
ALWAYS maintain unit in safe operating condition. Damaged or worn out muffler can cause fire or explosion.
This product is equipped with an internal combustion type engine. DO NOT use unit on or near any unimproved, forest-covered or brush-covered land unless exhaust system is equipped with a spark arrester meeting applicable local, state or federal laws. A spark arrester, if it is used, must be maintained in effective working order by operator.
DO NOT operate machine while feeling tired, ill or under the influence of alcohol or other drugs.
DO NOT put hands or feet near rotating parts or under the machine. Keep clear of the discharge opening at all times.

DO NOT touch parts which are hot. Allow parts to cool.
DO NOT operate machine without the entire grass catcher, discharge guard or other safety devices in place and working.
ALWAYS keep hands and feet away from all pinch points.
Avoid slippery surfaces. ALWAYS be sure of your footing.
NEVER carry passengers.
NEVER direct discharged material toward anyone. Avoid discharging material against a wall or obstruction. Material may ricochet back toward the operator. Stop the blade(s) when crossing gravel surfaces.
NEVER engage PTO when attachment, including mower blades, is not in use. ALWAYS turn off power to attachment when not in active use such as traveling or crossing driveways.
ALWAYS disengage PTO, stop unit and engine, remove key, engage parking brake and allow moving parts to stop before leaving operator's position.
NEVER engage PTO while raising the attachment, including mower blades, or when attachment is in the raised position.
Keep safety devices or guards in place and functioning properly. NEVER modify or remove safety devices.
DO NOT mow in reverse unless absolutely necessary. ALWAYS look down and behind before and while backing.
Stop engine before removing grass catcher or unclogging chute.
Slow down before turning.
If you strike a foreign object, stop and inspect the machine. Repair, if necessary, before restarting.
NEVER leave a running machine unattended. ALWAYS turn off blade(s), set parking brake, stop engine and remove key before dismounting.
Disengage blade(s) when not mowing. Shut off engine and wait for all parts to come to a complete stop before cleaning the machine, removing the grass catcher, or unclogging the discharge guard.
Know the weight of loads. Limit loads to those you can safely control and the unit can safely handle.

Operating Conditions
Lightning can cause severe injury or death. If lightning is seen or thunder is heard in the area, do not operate the machine, see shelter.
ALWAYS check overhead and side clearances carefully before operation.
Watch for traffic when operating near or crossing roadways.
Clear the area of objects such as rocks, wire, toys, etc., which could be thrown by the blades.
Check for weak spots on docks, ramps or floors. Avoid uneven work areas and rough terrain. Stay alert for hidden hazards or traffic.
Use care when approaching blind corners, shrubs, trees or other objects that may obscure vision.
Dust, smoke, fog, etc. can reduce vision and cause an accident.
Operate machine only in daylight or good artificial light.

Slope Operation
Slopes are a major factor related to loss of control and tip-over accidents, which can result in severe injury or death. Operation on all slopes requires extra caution. If you cannot back up the slope or if you feel uneasy on it, DO NOT mow it.
DO NOT operate on slopes of more than 15°.
Mow up and down slopes, not across.
ALWAYS keep the machine in gear when going down slopes. DO NOT shift to neutral and coast downhill.
Watch for holes, ruts, bumps, rocks, or other hidden objects. Uneven terrain could overturn the machine. Tall grass can hide obstacles.
DO NOT mow on moist or wet grass. Tires may lose traction causing a loss of control.
Use extra care while operating machine with grass catchers or other attachments; they can affect the stability of the machine. DO NOT use on steep slopes.
Keep all movements on the slope <i>slow</i> and <i>gradual</i> . DO NOT make sudden changes in speed or direction, which could cause the machine to roll over.

Avoid starting, stopping, or turning on a slope. If the tires lose traction, disengage the blade(s) and proceed slowly straight down the slope.
Operation on slopes may lead to loss of steering control. When operating on slopes be prepared to react to an emergency situation: <ul style="list-style-type: none"> • Return steering levers to neutral position. • Immediately set parking brake. • Turn off PTO and engine.
DO NOT try to stabilize the machine by putting your foot on the ground.
DO NOT park on slopes unless necessary. When parking on slope ALWAYS chock or block wheels. ALWAYS set parking brake.
Choose a low ground speed so you will not have to stop or shift while on a slope.
DO NOT mow near drop-offs, ditches, or embankments. The machine could suddenly roll over if a wheel goes over the edge or if the edge caves in.
DO NOT bypass transmission or allow transmission to free-wheel when on a slope.

Fuel
To avoid personal injury or property damage, use extreme care in handling gasoline. Gasoline is extremely flammable and the vapors are explosive.
Ethanol blends must not exceed E10. Higher ethanol content may cause your machine to run hotter and damage your engine.
Replace fuel cap securely and clean up spilled fuel before starting engine.
Extinguish all cigarettes, cigars, pipes and other sources of ignition.
Use only an approved gasoline container.
NEVER store the machine or fuel container where there is an open flame, spark or pilot light such as on a water or space heater or other appliances.
NEVER fill containers inside a vehicle or on a truck or trailer bed with a plastic liner. ALWAYS place containers on the ground away from your vehicle before filling.
NEVER fuel the machine indoors.
NEVER remove gas cap or add fuel with the engine running. Allow engine to cool before fueling.

Fuel is highly flammable and its vapors are explosive. Handle with care. Use only an approved gasoline container with an appropriately-sized dispensing spout. NO smoking, NO sparks, NO flames.
Remove gas-powered equipment from the trailer and refuel it on the ground. If this is not possible, then refuel such equipment with a portable container, rather than from a gasoline dispenser nozzle.
Keep the nozzle in contact with the rim of the fuel tank or container opening at all times until the fueling is complete. DO NOT use a nozzle lock-open device.
NEVER overfill fuel tank. Replace gas cap and tighten securely.
If fuel is spilled on clothing, change clothing immediately.

Towing
Follow the manufacturer's recommendations for weight limits for towed equipment and towing on slopes.
NEVER allow children or others in or on towed equipment.
Tow only with a machine that has a hitch designed for towing. DO NOT attach towed equipment except at the hitch point.
On slopes, the weight of the towed equipment may cause loss of traction and loss of control.
Travel slowly and allow extra distance to stop.

Accessories
Follow the manufacturer's recommendation for wheel weights or counterweights.
Check grass catcher components and the discharge guard frequently and replace with the manufacturer's recommended parts, when necessary.
Use only Ariens Company-recommended attachments that are appropriate to your use and can be used safely in your application.

Batteries
Avoid electric shock. Objects contacting both battery terminals at the same time may result in injury and unit damage. DO NOT reverse battery connections.

Reverse connections may result in sparks which can cause serious injury. ALWAYS connect positive (+) lead of charger to positive (+) terminal, and negative (-) lead to negative (-) terminal.
ALWAYS disconnect negative (-) cable FIRST and positive (+) cable SECOND. ALWAYS connect positive (+) cable FIRST, and negative (-) cable SECOND.
Explosive gases from battery can cause death or serious injury. Poisonous battery fluid contains sulfuric acid and its contact with skin, eyes or clothing can cause severe chemical burns.
No flames, No sparks, No smoking near battery.
ALWAYS wear safety glasses and protective gear near battery. Use insulated tools.
ALWAYS keep batteries out of reach of children.
Battery posts, terminals and related accessories contain lead and lead compounds, chemicals known to the state of California to cause cancer and reproductive harm. Wash hands after handling.

Service
The use of non-genuine replacement parts or accessories could adversely affect machine operation and safety.
Do not change engine governor setting or overspeed the engine.
Maintain or replace safety and instruction labels as necessary.
Keep unit free of debris. Clean up oil or fuel spills.
ALWAYS block wheels and know all jack stands are strong and secure and will hold weight of unit during maintenance.
Release any pneumatic or hydraulic pressure from components slowly.
NEVER attempt to make any adjustments to unit while engine is running (except where specifically recommended). Stop engine, remove key and spark plug wire and wait for all moving parts to stop before servicing or cleaning.
Lower cutting deck unless a positive mechanical lock is used.
Allow engine to cool before servicing.
Moving parts can cut or amputate fingers or a hand. On multiblade mowers, rotation of one blade will cause all blades to rotate.

NEVER weld or straighten mower blades.
NEVER make adjustments or repairs with the engine running.
Mower blades are sharp. Wrap the blade or wear gloves, and use extra caution when servicing them.
ALWAYS keep body and hands away from pin holes or nozzles which eject hydraulic fluid under pressure.

Transporting Unit
Use extra care when loading or unloading the machine into a trailer or truck.
Secure unit chassis to transport vehicle. NEVER secure from rods or linkages that could be damaged.
DO NOT transport machine while engine is running.
ALWAYS turn off power to attachment and shut off fuel when transporting unit.

Storage
NEVER store unit with fuel in fuel tank inside a building where any ignition sources are present.
Keep machine free of grass, leaves or other debris build-up. Clean up oil or fuel spillage and remove any fuel-soaked debris. Allow machine to cool before storing.
For extended storage, close fuel shut off valve and clean unit thoroughly. See engine manual for proper storage.

CONTROLS AND FEATURES

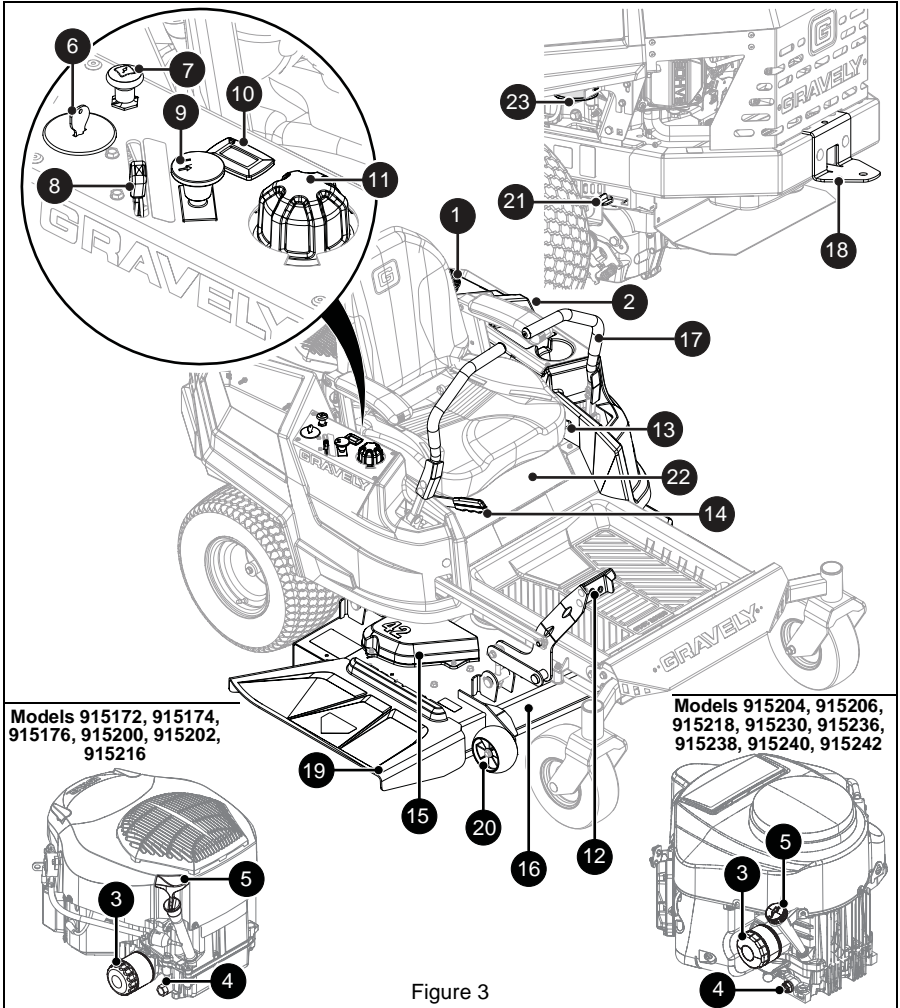

Figure 3

- | | |
|---|--|
| 1. Fuel Tank and Cap | 12. Deck Lift Pedal |
| 2. Fuel Level Window | 13. Seat Adjustment Lever |
| 3. Oil Filter | 14. Parking Brake Lever |
| 4. Oil Drain | 15. Belt Guard (2) |
| 5. Engine Oil Dipstick | 16. Mower Deck |
| 6. Ignition Key | 17. Steering Lever (2) |
| 7. Choke Control Knob (Models 915204,
915206, 915218, 915230, 915236,
915238, 915240, 915242) | 18. Towing / Trailer Hitch |
| 8. Throttle Control Lever | 19. Discharge Chute |
| 9. Power Take-off (PTO) Knob | 20. Anti-Scalp Roller (2) |
| 10. Hour Meter | 21. Transaxle Bypass Lever (2) |
| 11. Height-of-Cut Dial | 22. Battery (Under Seat) |
| | 23. Carbon Canister (Models 915176,
915236, 915238, 915240, 915242) |



WARNING: AVOID INJURY.
Read and understand the entire *Safety* section before proceeding.

See Figure 3 for all controls and features locations.

IGNITION KEY

See Figure 4.

Controls power to the engine. The key cannot be removed when in run position.

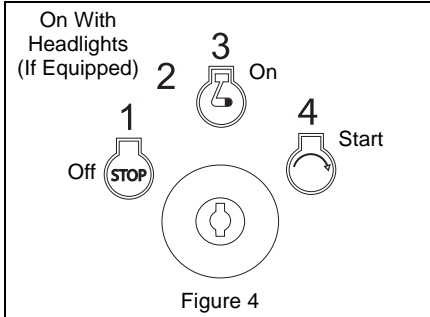

CHOKE CONTROL KNOB

Models 915204, 915206, 915218, 915230, 915236, 915238, 915240, 915242

See Figure 5.

Controls airflow to the engine.

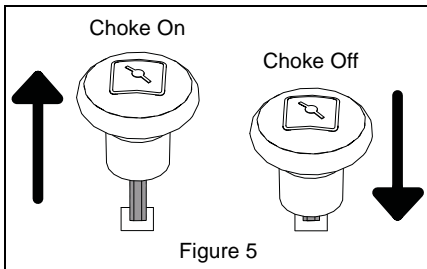

THROTTLE CONTROL LEVER

See Figure 6.

Controls engine speed.

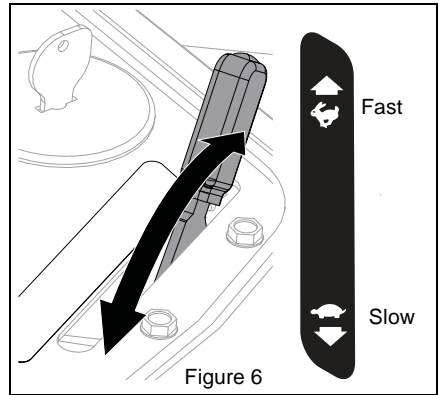

POWER-TAKE-OFF (PTO) KNOB

See Figure 7.

Controls power to mower blades. The engine will not start with the PTO knob in the on position.



WARNING: AVOID INJURY.
Blades will not *immediately* stop after pushing PTO knob down to off position.

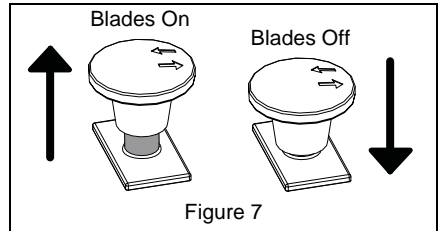

HOUR METER

Hour meter measures engine runtime and cannot be reset.

HEIGHT-OF-CUT DIAL

Sets the mower height of cut.

DECK LIFT PEDAL

Raises or lowers mower deck.

SEAT ADJUSTMENT LEVER

Unlocks seat to allow operator to move seat forward or backward and then lock in desired position.

PARKING BRAKE LEVER

See Figure 8.

Controls the parking brake. The engine will not start with brake in the off position.

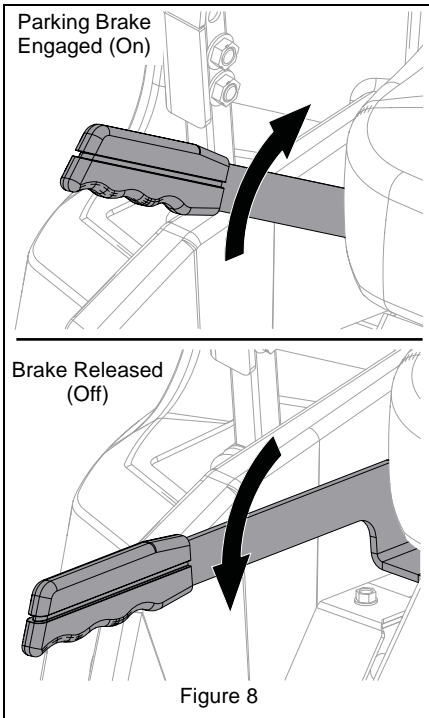

SAFETY INTERLOCK SYSTEM

Monitors the interaction of various unit features for operator safety.

STEERING LEVERS

Control the direction and speed of unit. The levers gradually return to neutral when released and are locked in neutral when parking brake is set.

TRANSAXLE BYPASS LEVERS

Control the transaxles so unit may be moved with the engine off.

ANTI-SCALP ROLLERS

Help prevent the deck from contacting the ground and scalping the lawn when passing over a high spot.

OPERATION



WARNING: AVOID INJURY.
Read and understand the *Safety* section before proceeding.

IMPORTANT: All references to left, right, front or rear are given from the perspective of operator in operator's position, facing the direction of forward travel.

EMERGENCY STOPPING

1. Move steering levers to neutral position.
2. Engage parking brake.
3. Push PTO knob down to off position.
4. Turn ignition key to off position and remove key from ignition.

BEFORE OPERATING UNIT

1. Check fuel level and add fuel if needed.

IMPORTANT: Use fresh unleaded fuel with an octane rating of at least 87. DO NOT use E85 blended fuels; the engine is not E20 / E30 / E85 compatible. The maximum recommended ethanol content is 10%. Gravely recommends using a quality fuel stabilizer in all fuel. See *Short-Term Storage* on page 36.

2. Check engine oil level and add oil if needed. Refer to engine manual.
3. Check condition of air cleaner. Refer to engine manual.
4. Check function of the Safety Interlock System by performing the tests in *Check Safety Interlock System* on page 20. Contact your Gravely dealer for repair if any of the tests fail.
5. Set cutting height. See Figure 9.
 - a. Depress and hold deck lift pedal in forward position.
 - b. Rotate height-of-cut dial to desired setting.
 - c. Slowly return deck lift pedal to resting position.

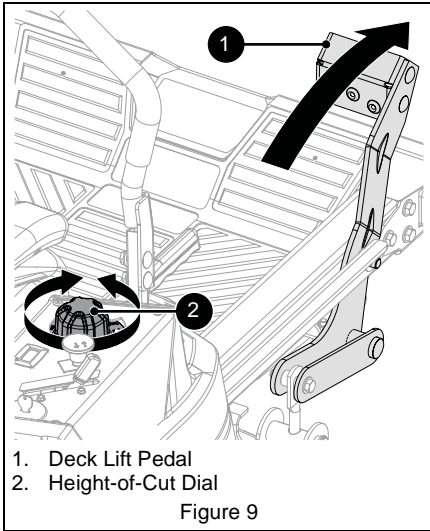

START THE ENGINE

1. Push PTO knob down to off position.
2. Move steering levers to neutral position.
3. Engage parking brake.
4. *Models 915204, 915206, 915218, 915230, 915236, 915238, 915240, 915242:* If engine is cold, pull choke knob up to on position. If engine is warm or hot, turn choke off.
5. Set throttle to slow speed.
6. Insert ignition key and turn to start position. Release key when engine starts.

IMPORTANT: Do not operate the starter for more than 10 seconds at a time. If the engine does not start, allow a 60-second cool down period between starting attempts.

7. *Models 915204, 915206, 915218, 915230, 915236, 915238, 915240, 915242:* If choke is on, wait a few seconds after engine starts and then push choke knob down to off position.

IMPORTANT: Make sure choke is completely off. Engine will not run smoothly using partial choke.

OPERATE UNIT

1. Release parking brake.





WARNING: AVOID INJURY.
Move the steering levers slowly and keep the throttle at slow speed until you learn how to operate the unit.

2. Set throttle to slow speed.
3. Pull PTO knob up to on position.

IMPORTANT: Never engage the PTO if the mower is plugged with grass or other material. This may cause damage to the electric clutch.

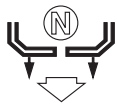
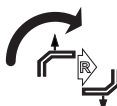
4. Move steering levers to begin mowing.

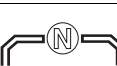
Direction of Travel	Lever Position
Forward	Push both levers forward from neutral position. 
Reverse	Pull both levers backward from neutral position. 
Right Turn	Push left lever farther forward than the right lever. 
Left Turn	Push right lever farther forward than the left lever. 
Stop	Return both levers to neutral position. 

5. Move throttle control lever to fast.

IMPORTANT: Aggressive turning can scuff or damage lawns. Always keep both wheels rotating when making sharp turns. **DO NOT** make turns with inside wheel completely stopped. For minimum turning radius, slowly reverse inside wheel while moving outside wheel slowly forward.

For Best Mowing Results

- Cut grass when it is dry.
- Keep mower blades sharp.
- Keep mower deck properly leveled.
- Do not set height of cut too low. For very tall grass, mow twice.
- Do not travel too fast.
- Mow with the engine set at full throttle.
- When mulching, only remove 1/3 of grass length per cutting. Do not cut more than 2.5 cm (1") at any one time.
- Discharge clippings into areas already cut.
- Vary cutting pattern with each mowing.
- Do not allow grass or debris to collect inside of mower deck. Clean after each use.

STOP THE ENGINE



WARNING: AVOID INJURY.
Wait for all moving parts to stop before leaving operator's position.

1. Move steering levers to neutral position.
2. Engage parking brake.
3. Push PTO knob down to off position.
4. Set throttle to slow speed.
5. Turn ignition key to off position and remove key from ignition.

MOVE UNIT MANUALLY

See Figure 10 and See Figure 11.

IMPORTANT: There is one transaxle bypass lever on each side of unit. Ensure that both levers are fully in front or rear position.

- To disengage the transaxles and move unit with the engine off, place both bypass levers in the rear position.
- To engage transaxles and operate unit normally, place both bypass levers in the front position.

Models 915200, 915202, 915204, 915206, 915216, 915218, 915238, 915240, 915242

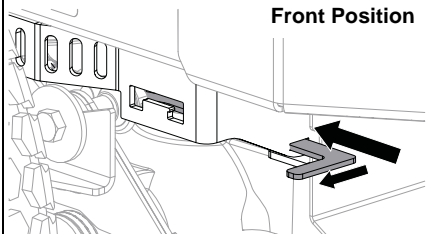
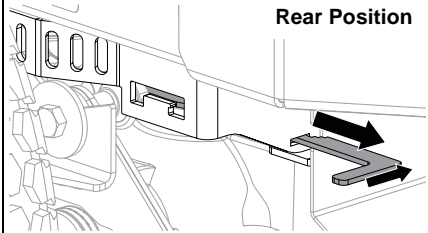
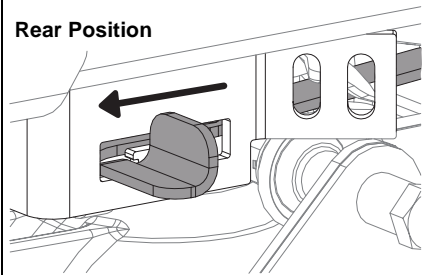

Figure 10

Models 915172, 915174, 915176, 915230, 915236

Rear Position



Front Position

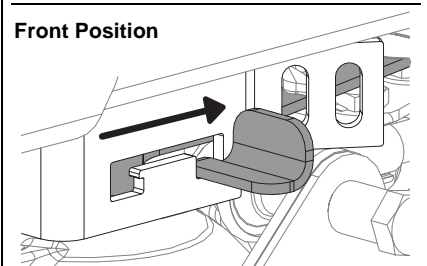

Figure 11

TRANSPORT UNIT

1. Stop engine, set parking brake and remove key from ignition.
2. Secure unit chassis to transport vehicle.

NOTICE: NEVER secure from rods or linkages that could be damaged.

MAINTENANCE



WARNING: AVOID INJURY.
Read and understand the *Safety* section before proceeding.

Your Gravely dealer can provide service and adjustments to keep your unit operating at peak efficiency.

Contact an authorized engine manufacturer's service center for engine service.

MAINTENANCE SCHEDULE

Service Performed	Each Use	Every 25 hrs.	Every 50 hrs.	Every 100 hrs.	Every 400 hrs.
Check Safety Interlock System	•				
Check Parking Brake	•				
Check Engine Oil *	•				
Change Engine Oil *+					
Check Tire Pressure	•				
Check Mower Blades	•				
Check Battery		•			
Clean Battery		•			
Check Carbon Canister Filter			•		
Check Air Filter *			•		
Check Fasteners			•		
Lubricate Unit			•		
Clean Engine Cooling System*				•	
Check Belts				•	
Change Hydraulic Oil and Filter (XL Models) **					•

* Refer to engine manual for instructions.

+ Use tubing included in literature pack to drain engine oil.

**Change after first 75 hours of operation.

SERVICE PARTS

See your Gravely dealer to purchase service parts for your unit.

Common Service Parts

Description	Qty.	Part No.
Fuel Stabilizer – 118 ml (4 oz)	A/R	
• Except Canada		04730300
• For Canada Only		04742400
Seat Switch	1	02754100

Model 915172

Description	Qty.	Part No.
Drive Belt	1	07200718
Mower Belt	1	07200523
Mower Blade	1	04769800
Front Wheel and Tire Assembly	1	07101127
Drive Wheel and Tire Assembly	1	07101130
Armrest Kit – Left	1	51528800
Armrest Kit – Right	1	51528900
Spark Plug	1	20934100
Fuel Filter	1	21539500
Oil Filter	1	21550800
Air Filter	1	21555300
Pre-Cleaner	1	21555400

Model 915174

Description	Qty.	Part No.
Drive Belt	1	07200718
Mower Belt	1	07200023
Mower Blade	1	04771200
Front Wheel and Tire Assembly	1	07101127
Drive Wheel and Tire Assembly	1	07101130
Armrest Kit – Left	1	51528800
Armrest Kit – Right	1	51528900
Spark Plug	1	20934100
Fuel Filter	1	21539500
Oil Filter	1	21550800
Air Filter	1	21555300
Pre-Cleaner	1	21555400

Model 915176

Description	Qty.	Part No.
Drive Belt	1	07200718
Mower Belt	1	07200523
Mower Blade	1	04769800
Front Wheel and Tire Assembly	1	07101127
Drive Wheel and Tire Assembly	1	07101130
Armrest Kit – Left	1	51528800
Armrest Kit – Right	1	51528900
Spark Plug	1	20934100
Fuel Filter	1	21539500
Oil Filter	1	21550800
Air Filter	1	21555300
Pre-Cleaner	1	21555400

Model 915200

Description	Qty.	Part No.
Drive Belt	1	07200724
Mower Belt	1	07200023
Mower Blade	1	04771200
Front Wheel and Tire Assembly	1	07101105
Drive Wheel and Tire Assembly	1	07101203
Armrest Pad – Left	1	21559500
Armrest Pad – Right	1	21559700
Armrest Kit – Left	1	51530000
Armrest Kit – Right	1	51530100
Seatback Cushion	1	21560600
Seat Bottom Cushion	1	21560800
Hydraulic Oil Filter	2	21545100
Hydraulic Oil (32 oz)	AR	00057100
Spark Plug	1	20934100
Fuel Filter	1	21539500
Oil Filter	1	21550800
Air Filter	1	21555300
Pre-Cleaner	1	21555400

Model 915202

Description	Qty.	Part No.
Drive Belt	1	07200804
Mower Belt	1	07200523
Mower Blade	1	04769800

Description	Qty.	Part No.
Front Wheel and Tire Assembly	1	07101105
Drive Wheel and Tire Assembly	1	07101122
Armrest Pad – Left	1	21559500
Armrest Pad – Right	1	21559700
Armrest Kit – Left	1	51530000
Armrest Kit – Right	1	51530100
Seatback Cushion	1	21560600
Seat Bottom Cushion	1	21560800
Hydraulic Oil Filter	2	21545100
Hydraulic Oil (32 oz)	AR	00057100
Spark Plug	1	20934100
Fuel Filter	1	21539500
Oil Filter	1	21550800
Air Filter	1	21555300
Pre-Cleaner	1	21555400

Model 915204

Description	Qty.	Part No.
Drive Belt	1	07200724
Mower Belt	1	07200023
Mower Blade	1	04771200
Front Wheel and Tire Assembly	1	07101105
Drive Wheel and Tire Assembly	1	07101203
Armrest Pad – Left	1	21559500
Armrest Pad – Right	1	21559700
Armrest Kit – Left	1	51530000
Armrest Kit – Right	1	51530100
Seatback Cushion	1	21560600
Seat Bottom Cushion	1	21560800
Hydraulic Oil Filter	2	21545100
Hydraulic Oil (32 oz)	AR	00057100
Spark Plug	1	21536100
Fuel Filter	1	21548101
Oil Filter	1	21548100
Air Filter	1	21548000

Model 915206

Description	Qty.	Part No.
Drive Belt	1	07200724
Mower Belt	1	07200523
Mower Blade	1	04769800

Description	Qty.	Part No.
Front Wheel and Tire Assembly	1	07101105
Drive Wheel and Tire Assembly	1	07101122
Armrest Pad – Left	1	21559500
Armrest Pad – Right	1	21559700
Armrest Kit – Left	1	51530000
Armrest Kit – Right	1	51530100
Seatback Cushion	1	21560600
Seat Bottom Cushion	1	21560800
Hydraulic Oil Filter	2	21545100
Hydraulic Oil (32 oz)	AR	00057100
Spark Plug	1	21536100
Fuel Filter	1	21548101
Oil Filter	1	21548100
Air Filter	1	21548000

Model 915216

Description	Qty.	Part No.
Drive Belt	1	07200724
Mower Belt	1	07200804
Mower Blade	1	04965000
Front Wheel and Tire Assembly	1	07101105
Drive Wheel and Tire Assembly	1	07101213
Armrest Pad – Left	1	21559500
Armrest Pad – Right	1	21559700
Armrest Kit – Left	1	51530000
Armrest Kit – Right	1	51530100
Seatback Cushion	1	21560600
Seat Bottom Cushion	1	21560800
Hydraulic Oil Filter	2	21545100
Hydraulic Oil (32 oz)	AR	00057100
Spark Plug	1	20934100
Fuel Filter	1	21539500
Oil Filter	1	21550800
Air Filter	1	21555300
Pre-Cleaner	1	21555400

Model 915218

Description	Qty.	Part No.
Drive Belt	1	07200724
Mower Belt	1	07200804
Mower Blade	1	04965000

Description	Qty.	Part No.
Front Wheel and Tire Assembly	1	07101105
Drive Wheel and Tire Assembly	1	07101213
Armrest Pad – Left	1	21559500
Armrest Pad – Right	1	21559700
Armrest Kit – Left	1	51530000
Armrest Kit – Right	1	51530100
Seatback Cushion	1	21560600
Seat Bottom Cushion	1	21560800
Hydraulic Oil Filter	2	21545100
Hydraulic Oil (32 oz)	AR	00057100
Spark Plug	1	21536100
Fuel Filter	1	21548101
Oil Filter	1	21548100
Air Filter	1	21548000

Model 915230

Description	Qty.	Part No.
Drive Belt	1	07200718
Mower Belt	1	07200023
Mower Blade	1	04771200
Front Wheel and Tire Assembly	1	07101127
Drive Wheel and Tire Assembly	1	07101130
Armrest Kit – Left	1	51528800
Armrest Kit – Right	1	51528900
Spark Plug	1	21536100
Fuel Filter	1	21539500
Oil Filter	1	21548100
Air Filter	1	21548000

Model 915236

Description	Qty.	Part No.
Drive Belt	1	07200718
Mower Belt	1	07200023
Mower Blade	1	04771200
Front Wheel and Tire Assembly	1	07101127
Drive Wheel and Tire Assembly	1	07101130
Armrest Kit – Left	1	51528800
Armrest Kit – Right	1	51528900
Spark Plug	1	21536100
Fuel Filter	1	21548101
Oil Filter	1	21548100
Air Filter	1	21548000

Model 915238

Description	Qty.	Part No.
Drive Belt	1	07200724
Mower Belt	1	07200523
Mower Blade	1	04769800
Front Wheel and Tire Assembly	1	07101105
Drive Wheel and Tire Assembly	1	07101213
Armrest Pad – Left	1	21559500
Armrest Pad – Right	1	21559700
Armrest Kit – Left	1	51530000
Armrest Kit – Right	1	51530100
Seatback Cushion	1	21560600
Seat Bottom Cushion	1	21560800
Hydraulic Oil Filter	2	21545100
Hydraulic Oil (32 oz)	AR	00057100
Spark Plug	1	21536100
Fuel Filter	1	21548101
Oil Filter	1	21548100
Air Filter	1	21548000

Model 915240

Description	Qty.	Part No.
Drive Belt	1	07200724
Mower Belt	1	07200023
Mower Blade	1	04771200
Front Wheel and Tire Assembly	1	07101105

Description	Qty.	Part No.
Drive Wheel and Tire Assembly	1	07101213
Armrest Pad – Left	1	21559500
Armrest Pad – Right	1	21559700
Armrest Kit – Left	1	51530000
Armrest Kit – Right	1	51530100
Seatback Cushion	1	21560600
Seat Bottom Cushion	1	21560800
Hydraulic Oil Filter	2	21545100
Hydraulic Oil (32 oz)	AR	00057100
Spark Plug	1	21536100
Fuel Filter	1	21548101
Oil Filter	1	21548100
Air Filter	1	21548000

Model 915242

Description	Qty.	Part No.
Drive Belt	1	07200724
Mower Belt	1	07200804
Mower Blade	1	04965000
Front Wheel and Tire Assembly	1	07101105
Drive Wheel and Tire Assembly	1	07101213
Armrest Pad – Left	1	21559500
Armrest Pad – Right	1	21559700
Armrest Kit – Left	1	51530000
Armrest Kit – Right	1	51530100
Seatback Cushion	1	21560600
Seat Bottom Cushion	1	21560800
Hydraulic Oil Filter	2	21545100
Hydraulic Oil (32 oz)	AR	00057100
Spark Plug	1	21536100
Fuel Filter	1	21548101
Oil Filter	1	21548100
Air Filter	1	21548000

SERVICE POSITION

See Figure 12.

Before starting any of the following maintenance procedures:

1. Park unit a flat, level surface.
2. Stop engine, remove key and wait for all moving parts to stop and for hot parts to cool.
3. Move steering levers to neutral position and rotate handles outward.
4. Engage parking brake.
5. Disconnect spark plug wires from engine.
6. Tip seat forward.

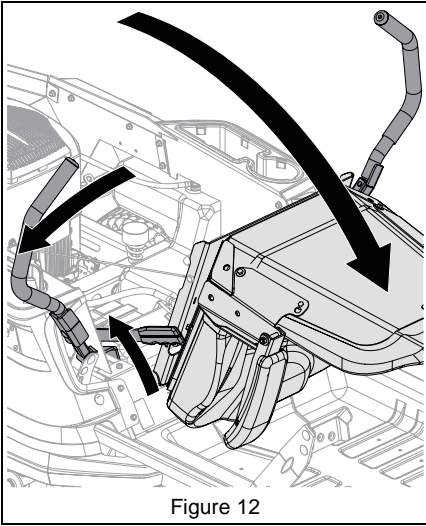

Figure 12

IMPORTANT: Reconnect spark plug wires after maintenance.

CHECK SAFETY INTERLOCK SYSTEM

Check function of the Safety Interlock System by performing the tests below. Contact your Gravely dealer for repair if any of the tests fail.

Test	Steering Levers	PTO	Parking Brake	Result
Starting Interlock				
1	Neutral	Off	On	Engine starts.
2	Forward, Neutral, Reverse	On	On or Off	Engine does not start.
3	Forward, Neutral, Reverse	On or Off	Off	Engine does not start.
Operating Interlock (Engine On)				
4 *	Forward, Neutral, Reverse	On	On or Off	Engine shuts off.
5 *	Forward, Neutral, Reverse	On or Off	Off	Engine shuts off.
* When operator lifts off seat.				

CHECK PARKING BRAKE

1. Place unit in service position. See *Service Position* on page 20.
2. Set both transaxle bypass levers in the rear position. See *Move Unit Manually* on page 15.
3. Push unit forward.
 - If unit does not move forward, no further action is needed.
 - If unit easily moves forward, adjust the brake lever. See *Adjust Parking Brake Lever* on page 30.

CHECK ENGINE OIL

NOTICE: Engine oil level must be maintained at correct level or engine damage may occur. Refer to engine manual.

CHECK TIRE PRESSURE

See *Specifications* on page 37 for recommended tire pressure.



WARNING: AVOID INJURY.
Explosive separation of tire and rim parts is possible.

- DO NOT inflate tires above the recommended pressure.
- DO NOT inflate tires with a compressor; use a hand pump.
- DO NOT stand in front of tire assembly when inflating. Use a clip-on chuck and extension hose long enough to allow you to stand to one side.
- DO NOT mount a tire without proper equipment and experience.

CHECK CARBON CANISTER FILTER

Models 915176, 915236, 915238, 915240, 915242

See Figure 13.

Clean or replace filter whenever engine air filter is cleaned or replaced.

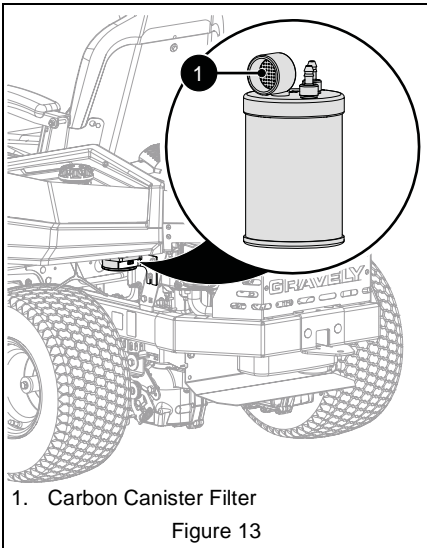

CHECK FASTENERS

Check for loose or missing hardware.

LUBRICATE UNIT

See Figure 14.

1. Place unit in service position. See *Service Position* on page 20.
2. Apply grease to seat tracks through slots under seat plate.

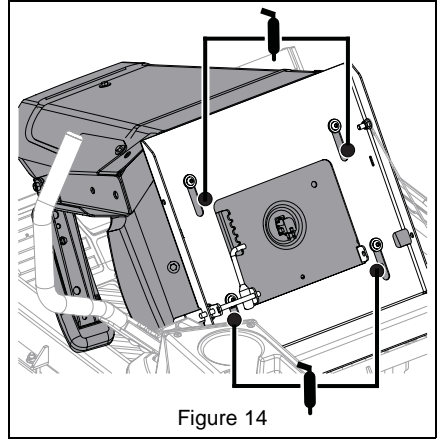

3. Return seat to operating position and slide seat back and forth to spread grease along tracks.

CHECK MOWER BLADES

Check blades for wear. Replace or sharpen as needed.



CAUTION: AVOID INJURY. Use sturdy gloves or padding to protect hands when working with mower blades.

Rotation of one blade rotates the other blades.

Remove Blades

See Figure 15.

1. Stop engine, remove key and wait for all moving parts to stop and for hot parts to cool.
2. Remove hardware securing blades to spindles and remove blades. Retain all hardware for reinstallation.

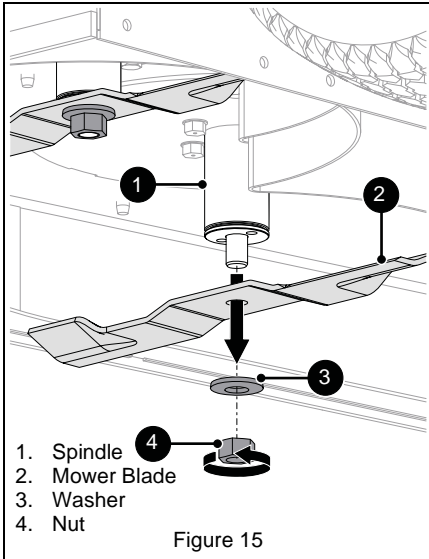

Sharpen Blades



CAUTION: DO NOT sharpen blades while attached to unit.

See Figure 16.

1. Remove blades from unit. Discard blades if:
 - More than 1.3 cm (1/2") of metal is removed.
 - Air lifts are eroded.
 - Blades are bent or broken.

2. File or grind an equal amount of material from each cutting edge of the blade until sharp. DO NOT change angle of cutting edge or round the corner of the blade.

DO NOT sharpen to this pattern.

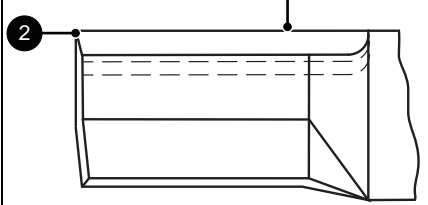

Sharpen to this pattern.

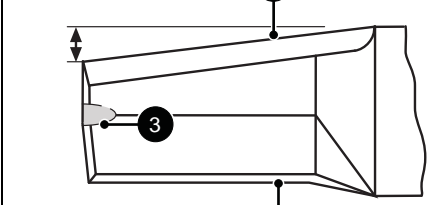

1. Cutting Edge
2. Square Corner
3. Air Lift Erosion
4. Air Lift

Figure 16



CAUTION: Unbalanced blades cause excessive vibration and eventual damage to unit.

Balance blades before reinstalling on unit.
NEVER weld or straighten blades.

3. Check blade balance by sliding blade on an unthreaded bolt. If blade does not remain horizontal, sharpen the heavy end until blade is balanced.

Install Blades

1. Reinstall blades, washers and nuts on spindles. See Figure 15.
2. Torque bolts to 136 – 163 N•m (100 – 120 lb-ft).

CHECK BATTERY



WARNING: Battery posts, terminals and related accessories contain lead and lead compounds, chemicals known to the State of California to cause cancer and reproductive harm. Wash hands after handling.

Remove Battery

1. Place unit in service position. See *Service Position* on page 20.
2. Disconnect the negative cable and then the positive cable from the battery.

See Figure 17.

3. Remove hardware retaining battery brackets and remove brackets.

IMPORTANT: Remove flange nuts and brackets only. DO NOT remove bolts from battery tray.

4. Remove battery.

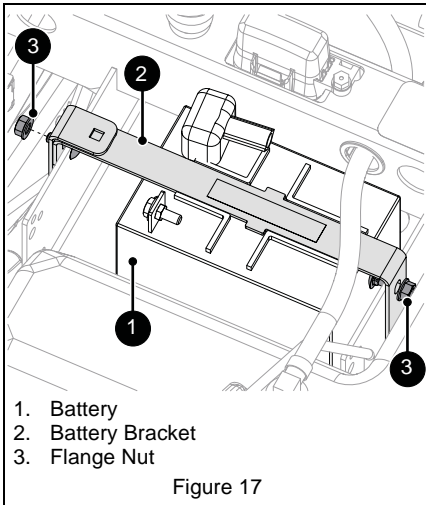

Install Battery

Install Factory Battery

Battery bracket configurations for a U1 battery and a factory-installed battery are different. If replacing a U1 battery with a factory-installed battery, see step 1. If a factory-installed battery was most recently used, advance to step 2.

1. Remove hardware retaining L-bracket to battery bracket and reinstall hardware into L-bracket hole nearest curved edge. See Figure 18.

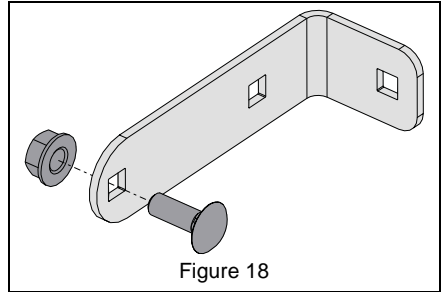

See Figure 19.

2. Place battery on battery tray so terminals are positioned nearest right side of unit.
3. Install battery bracket over battery and onto bolts in battery tray.
4. Reinstall L-bracket onto bolt and secure with flange nut.
5. Secure remaining battery bracket end to battery tray with original flange nut.
6. Connect positive cable to positive battery terminal and then the negative cable to negative battery terminal.
7. Return seat to operating position.

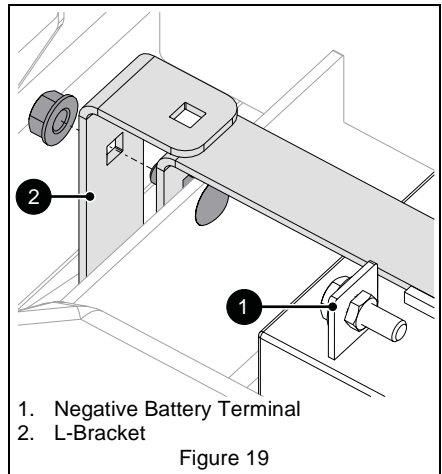

Install U1 Battery

1. Remove factory battery. See *Remove Battery* on page 23.
2. Remove hardware from L-bracket and secure L-bracket to battery bracket. See Figure 20.

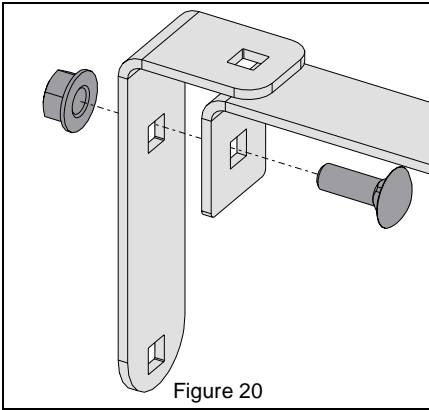
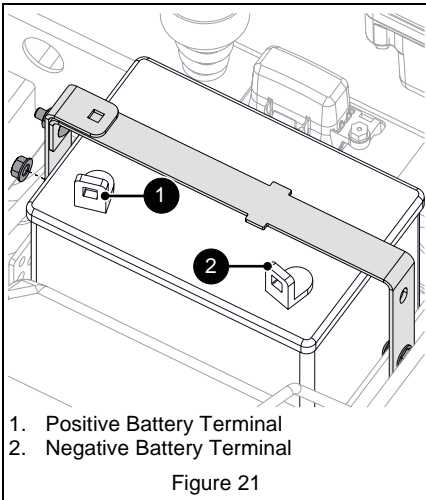

Figure 20

3. Place U1 battery in battery tray so terminals are positioned toward the front of unit.
4. Install battery bracket over battery and onto bolts in battery tray. Secure with two flange nuts. See Figure 21.



1. Positive Battery Terminal
2. Negative Battery Terminal

Figure 21

5. Connect positive cable to positive battery terminal and then the negative cable to negative battery terminal.
6. Return seat to operating position.

Clean Battery

1. Remove battery from unit. See *Remove Battery* on page 23.
2. Clean terminals and battery cable ends with a wire brush.
3. Coat terminals with dielectric grease or petroleum jelly.

4. Reinstall battery. See *Install Battery* on page 23.

Charge Battery

Check battery with a voltmeter. If battery is less than 11 volts, charge battery.

NOTICE: DO NOT fast charge. Charging at a higher rate damages or destroys the battery. ONLY use an automatic charger designed for use with your battery.

IMPORTANT: Always follow information provided on battery by battery manufacturer. Contact battery manufacturer for detailed information about charging.

IMPORTANT: Gravely does not recommend jump starting your unit. Jump-starting can damage engine and system components. Refer to engine manual for detailed information.

1. Remove battery from unit. See *Remove Battery* on page 23.
2. Place battery on bench or other well-ventilated area.
3. Connect positive lead of charger to positive battery terminal.
4. Connect negative lead of charger to negative battery terminal.
5. Charge battery following battery manufacturer's instructions.
6. Reinstall battery. See *Install Battery* on page 23.

CHECK MOWER BELTS

Check belts for wear and replace as needed.

Remove Deck Drive Belt



CAUTION: Keep body parts away from idler when releasing idler spring tension.

1. Stop engine, remove key and wait for all moving parts to stop and for hot parts to cool.
2. Lower deck to lowest cutting height. See Figure 22.
3. Remove self-tapping screws from each belt cover and remove belt covers. Retain all parts for reinstallation.
4. Disconnect idler spring from spring bracket to release belt tension.

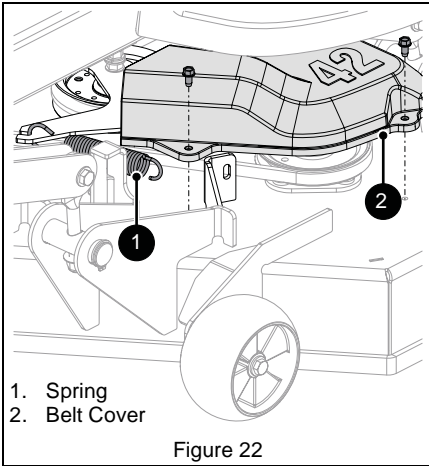

- Remove hardware retaining idler arm and two belt fingers from mower deck and remove idler arm and belt fingers. Retain all parts for reinstallation. See Figure 23.

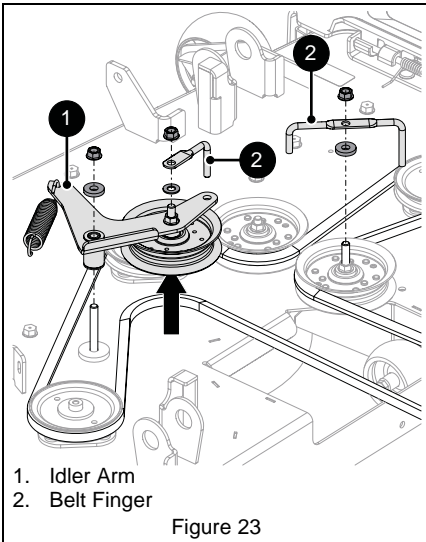

- Remove deck drive belt.

Install Deck Drive Belt

- Install deck drive belt. See Figure 24.

IMPORTANT: Belt will not have tension until routed around drive pulley and idler arm is reinstalled.

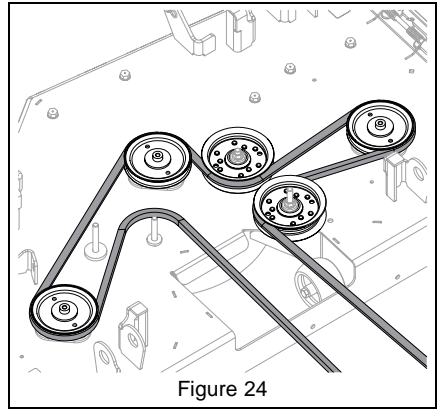

- Reinstall idler arm and belt fingers. See Figure 23.
- Secure idler spring to spring bracket so drive belt has tension. See Figure 25.

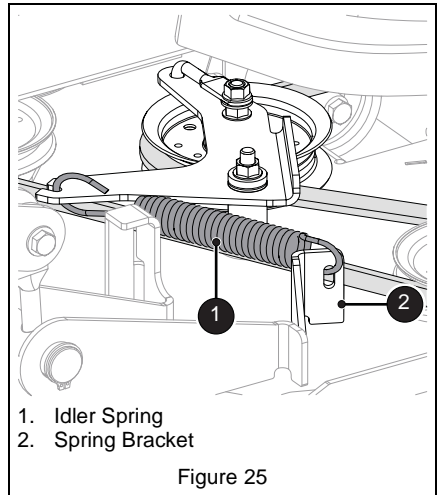

- Reinstall belt covers and secure each with self-tapping screws removed earlier.

IMPORTANT: Make sure belt has tension and remains aligned after installation is complete.

Remove Ground Drive Belt

IMPORTANT: Retain all parts for reinstallation.

- Place unit in service position. See *Service Position* on page 20.
- Remove deck drive belt. See *Remove Deck Drive Belt* on page 24.
- Loosen nut on eye bolt and disconnect idler arm spring. See Figure 26.

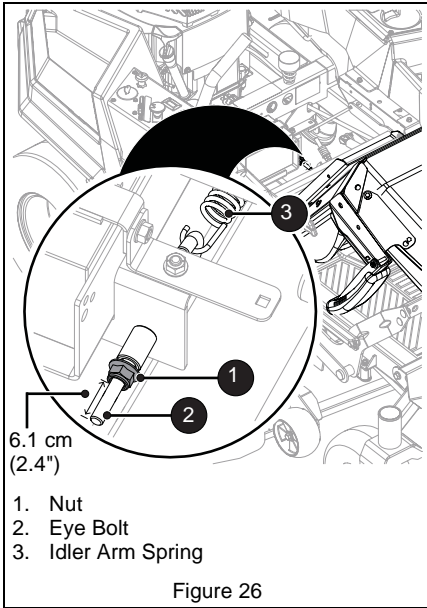

See Figure 27.

4. Remove the right-side self-tapping screw from heat shield and rotate shield out of the way.
5. Remove two self-tapping screws from clutch stop bracket and remove bracket.

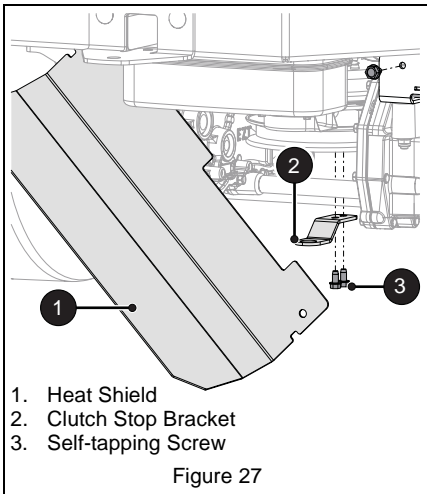

6. Disconnect clutch wire.
7. Remove ground drive belt.

NOTICE: Route the belt over the top of the pulleys for easiest removal.

Install Ground Drive Belt

1. Install ground drive belt. See Figure 28.

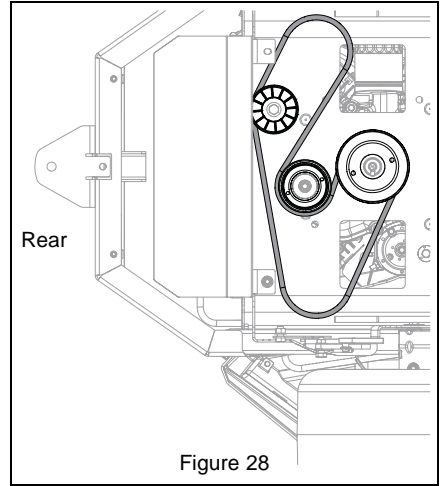

2. Reconnect clutch wire.
3. Reinstall clutch stop bracket and secure with two self-tapping screws removed earlier.
4. Rotate heat shield into position and secure to unit with self-tapping screw removed earlier.
5. Reconnect idler arm spring to eye bolt and secure bolt to unit with nut. Tighten until the nut is 6.1 cm (2.4") from the threaded end of the eye bolt. See Figure 26.
6. Reinstall deck drive belt. See *Install Deck Drive Belt* on page 25.

HYDRAULIC OIL

Models 915200, 915202, 915204, 915206, 915216, 915218, 915238, 915240, 915242

Check Hydraulic Oil Level

See Figure 29.

1. Place unit in service position. See *Service Position* on page 20.
2. Check oil level in expansion tanks. Oil should reach the cold fill indicator mark.

NOTICE: Engine should be cold when checking initial oil level.

3. Operate unit for about 1 minute and recheck the levels.
4. Add hydraulic oil, if needed. See *Add Hydraulic Oil* on page 27.

Add Hydraulic Oil

See Figure 29.

1. Place unit in service position. See *Service Position* on page 20.
2. Remove the cap from the expansion tank.
3. Fill the expansion tank with 15W-50 synthetic motor oil (Gravely p/n 00057100) or equivalent until oil level reaches the cold fill line on the tank.
4. Reinstall the expansion tank cap.

The hydraulic fluid should be at the cold fill line of the expansion tank.

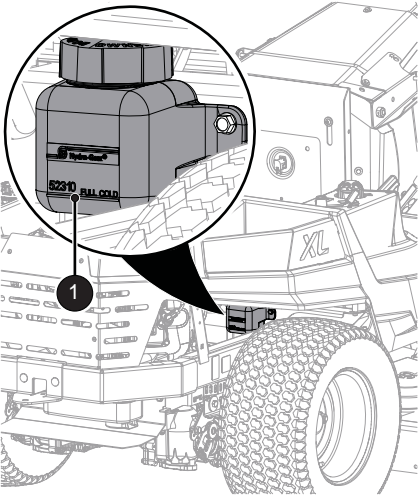

1. Cold Fill Indicator Mark

Figure 29

Change Hydraulic Oil and Filter

Models 915200, 915202, 915204, 915206, 915216, 915218, 915238, 915240, 915242

NOTICE: Change hydraulic fluid and filter after the first 75 hours of operation and then every 400 hours. Use 15W-50 synthetic motor oil (Gravely p/n 00057100) or equivalent.

1. Operate unit for a few minutes to warm hydraulic oil.
2. Stop engine, remove key and wait for all moving parts to stop and for hot parts to cool.
3. Position container under oil filter to catch used oil.

See Figure 30.

4. Remove filter guard and oil filter from transaxle.
5. Remove the vent plug from the inlet port and allow the transaxle to drain completely.

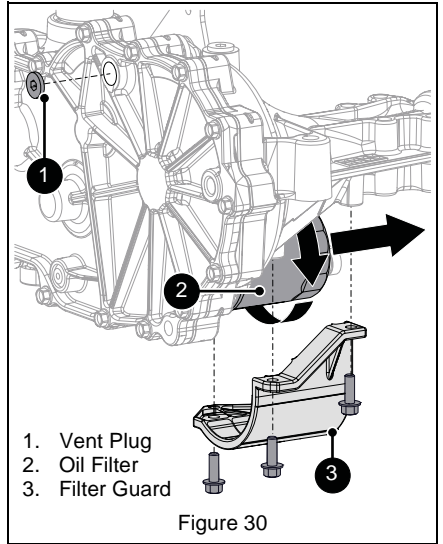

1. Vent Plug
2. Oil Filter
3. Filter Guard

Figure 30

6. Wipe filter-mounting surface clean.
7. Lubricate rubber gasket on new oil filter with clean hydraulic oil.
8. Spin filter onto filter housing until it makes contact, and then turn filter 3/4 turn to tighten.
9. Reinstall filter guard and torque to 7.3 N•m (65 lb-in). DO NOT overtighten.
10. Add 15W-50 synthetic motor oil (Gravely p/n 00057100) or equivalent until oil appears at the bottom of the vent port (1892.7 mL (64 fl. ounces) per transaxle).

11. Reinstall the vent plug and tighten to 20.3 N•m (180 lb-in).
12. Add hydraulic oil to expansion tank until oil reaches cold fill indicator mark. See *Add Hydraulic Oil* on page 27.
13. Repeat steps 3 – 12 for other transaxle.
14. Purge hydraulic system. See *Purge Hydraulic System* on page 28.

Purge Hydraulic System



WARNING: This adjustment requires operating the engine. Use extreme care to avoid contact with moving parts and hot surfaces. Be sure rear of unit is well supported and secure before starting engine.

1. With the unit up to and facing a wall, jack up the unit so that both drive wheels are off the ground.
2. Disengage the parking brake and put the transaxle bypass levers in the neutral position (see *Move Unit Manually* on page 15).
3. Start the engine and slowly move the steering levers in forward and reverse five or six times.
4. Stop the engine and put the transaxle bypass levers in the drive position (see *Move Unit Manually* on page 15).
5. Start the engine and slowly move the steering levers in forward and reverse five or six times.
6. Stop the engine, check the oil level and add oil as needed.
7. Repeat steps 2 – 6 until the transaxles operate smoothly in forward and reverse at normal speeds without excessive noise.

ADJUSTMENTS



WARNING: AVOID INJURY. Read and understand the *Safety* section before proceeding.

ADJUST SEAT

See Figure 31.

1. Pull seat adjustment lever up to unlock seat.
2. Move seat to desired position.
3. Release seat adjustment lever to lock seat in place.

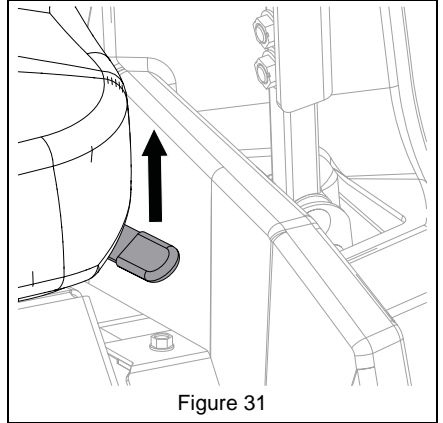

Figure 31

ADJUST STEERING LEVERS

Adjust Steering Lever Height

See Figure 32.

1. Remove hardware securing steering lever to upper control arm.
2. Place steering lever in desired adjusting hole.
 - Use upper and middle holes for highest lever position.
 - Use middle and lower holes for lowest lever position.
3. Reinstall hardware in upper control arm.
4. Align levers side to side. See *Adjust Steering Lever Reach* on page 29.
5. Fully tighten hardware.

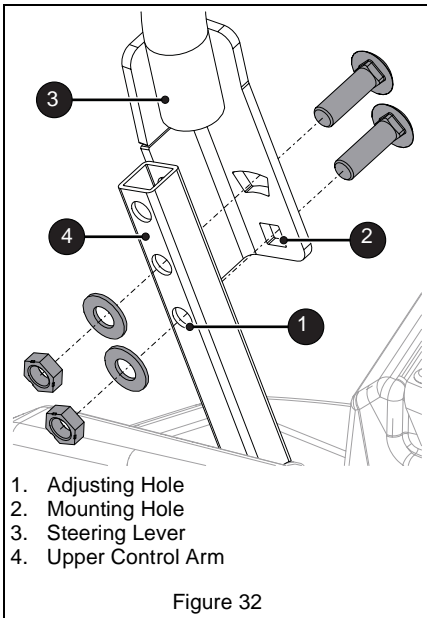

Adjust Steering Lever Reach

See Figure 34.

1. Loosen hardware securing steering lever to upper control arm.
2. Pivot steering lever to desired position. Ensure levers are aligned with each other.
3. Tighten hardware.

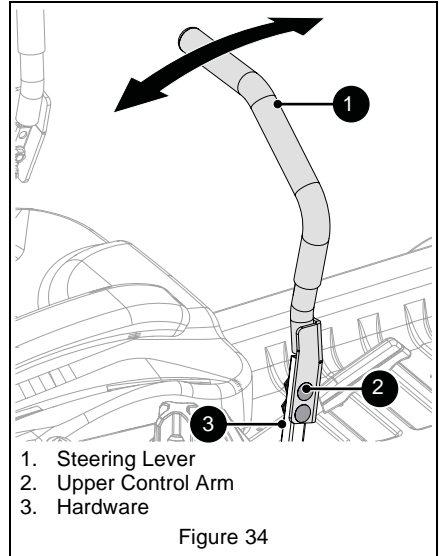

See Figure 33.

6. Loosen nut on hex bolt supporting eccentric spacer.
7. Rotate eccentric spacer around hex bolt until levers are at the same height.
8. Tighten nut.

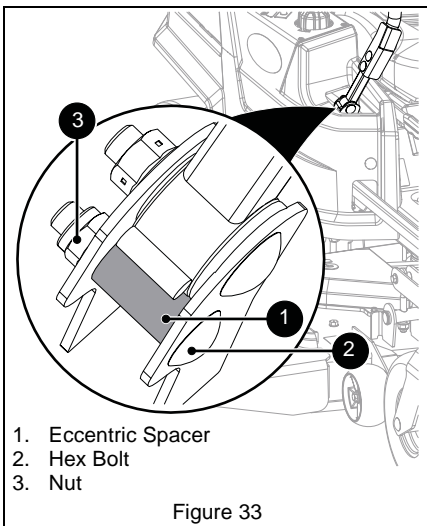

ADJUST UNIT TO TRACK STRAIGHT

NOTICE: Reverse travel can only be adjusted by your Gravely dealer.

Check Tire Pressure

1. Check pressure of both tires. See *Specifications* on page 37 for recommended tire pressure.
2. Recheck unit tracking. If unit still does not track straight, note which side the unit pulls toward and increase the tire pressure on that side.

IMPORTANT: DO NOT exceed maximum tire pressure listed on tire sidewall.

If increasing tire pressure on one side does not correct tracking problem, adjust the steering levers.

Adjust Steering Levers

See Figure 35.

If adjusting tire pressure did not correct tracking problem:

1. Loosen jam nut on adjustment bolt of steering lever that needs adjustment.
2. Adjust drive wheel speed.
 - Turn adjustment bolt counterclockwise to increase steering lever travel and drive wheel speed.
 - Turn adjustment bolt clockwise to decrease steering lever travel and drive wheel speed.
3. Tighten jam nut.

IMPORTANT: Adjustment bolt must contact steering lever. DO NOT turn adjustment bolt too far counterclockwise.

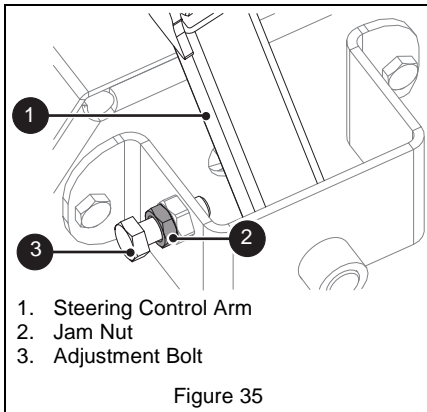

ADJUST PARKING BRAKE LEVER

1. Park unit a flat, level surface and chock wheels so unit cannot roll.
 2. Position deck at lowest cutting height.
- See Figure 36.
3. Loosen upper jam nut and adjust lower nut up or down until brake lever functions correctly.
 4. Tighten upper jam nut against lower nut.
 5. Return seat to operating position.

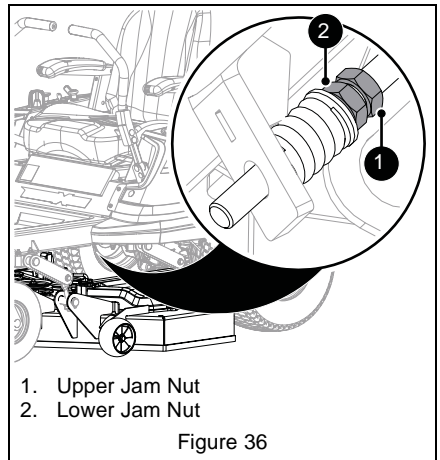

REMOVE AND INSTALL MOWER DECK

Remove Deck

1. Set deck to lowest cutting height.
2. Position supports, such as wood blocks, under mower deck.

See Figure 37.

3. Remove three self-tapping screws from left belt cover and remove belt cover. Retain all parts for reinstallation.
4. Disconnect idler spring from spring bracket to release belt tension.

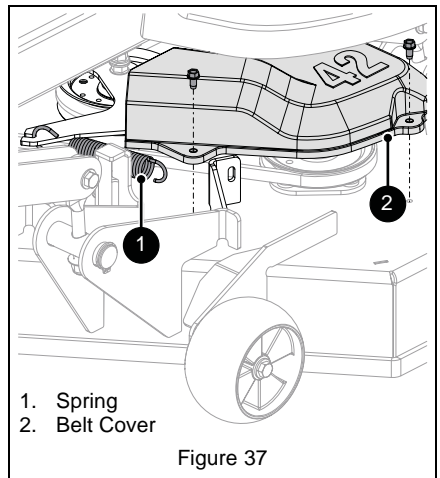

- Remove deck drive belt from rear drive pulley. See Figure 38.

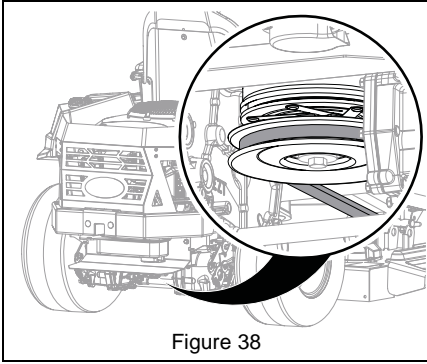

Figure 38

See Figure 39.

- Remove one hairpin from drag link to disconnect drag link from mower deck bracket. Retain all parts for reinstallation.
- Repeat step 6 on other side.

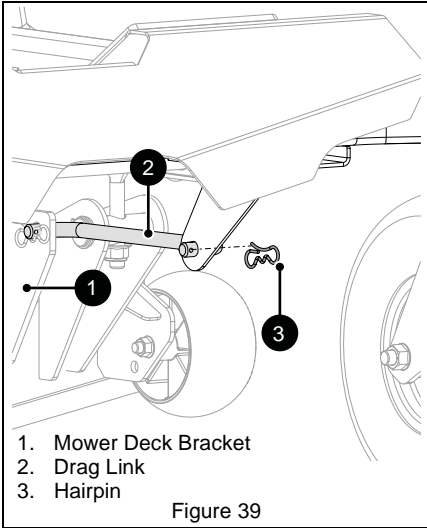

Figure 39

- Remove one flange nut, one hex bolt, one flat steel washer and two sleeve bushings from deck lift lever. Retain hardware. See Figure 40.

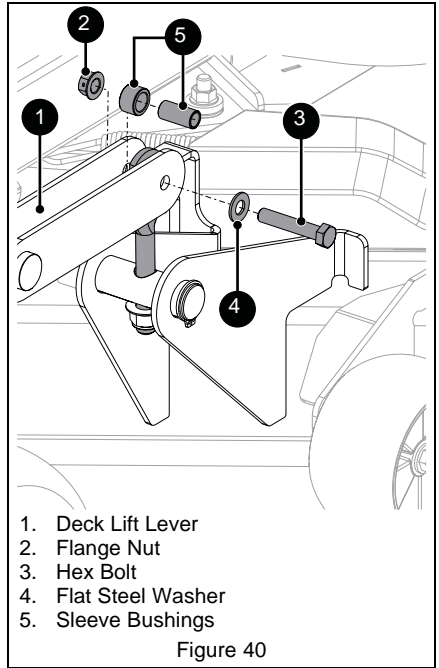

Figure 40

- Repeat step 8 for the three remaining deck lift levers.
- Move deck from under unit.

Install Deck

- Position deck under unit.

See Figure 41.

- Align holes in deck lift lever with slot in deck link.
- Position one 1/2 x 3/4 x 3/64" (shorter) sleeve bushing between deck link and interior bracket of deck lift lever.
- Insert 3/8 x 1/2 x 1" (longer) sleeve bushing through slot in deck link and shorter sleeve bushing.
- Insert hex bolt through washer, deck lift lever, deck link and sleeve bushings. Secure with flange nut.

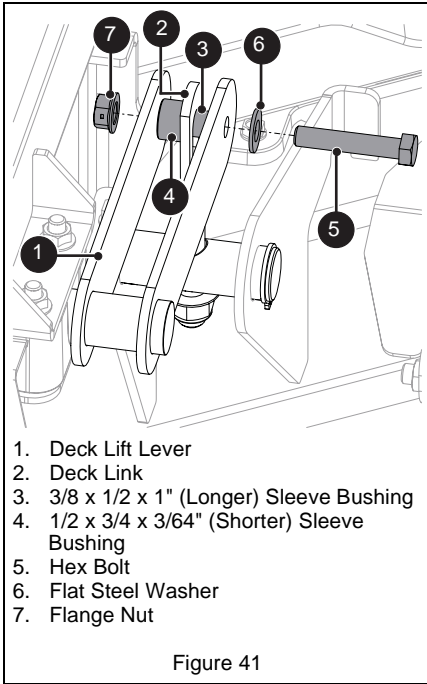

6. Repeat steps 2 – 5 for the three remaining deck lift levers.
7. Reinstall drag link through mower deck bracket and secure with hairpin removed earlier. See Figure 39.
8. Repeat step 7 on other side.
9. Secure drive belt around drive pulley.
10. Secure idler spring to spring bracket so drive belt has tension.
11. Reinstall belt cover and secure with three self-tapping screws removed earlier. See Figure 37.

ADJUST MOWER DECK



CAUTION: AVOID INJURY. Use sturdy gloves or padding to protect hands when working with mower blades. Rotation of one blade rotates the other blades.

Level Mower Deck

IMPORTANT: Make sure unit is on a flat, level surface and that tires are inflated to the recommended pressures. See *Specifications* on page 37

1. Set deck to highest cutting height.
2. Position mower blades so blade ends point left to right across the width of the deck.
3. On both sides of the unit, measure the distance to the ground at the cutting edge of the blade. See Figure 42.

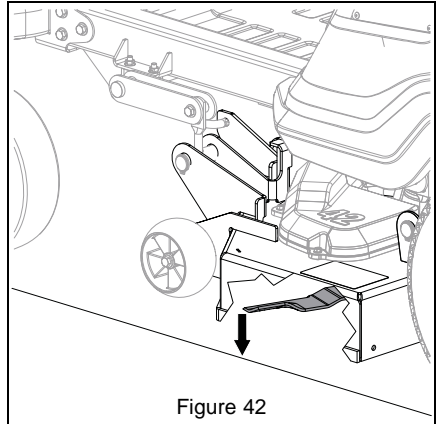

- If the measurements are ± 0.635 cm (1/4") of one another, no adjustment is needed.
- If adjustments are needed, adjust the nylon locking flange nut on the deck link. Tighten the nut to raise the deck; loosen the nut to lower the deck. See Figure 43.

IMPORTANT: It may be necessary to adjust the nut on more than one of the deck links.

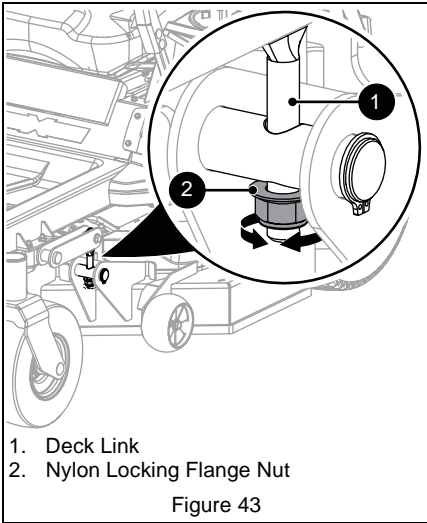

- If the front tip of the blade is ± 0.635 cm (1/4") lower than the rear, no adjustment is needed.
- If adjustments are needed, adjust the nylon locking flange nut on the deck link. Tighten the nut to raise the deck; loosen the nut to lower the deck. See Figure 43.

Set Blade Pitch

Pitch is the difference in blade height from front to back.

IMPORTANT: Level the mower deck before setting blade pitch.

1. Set deck to highest cutting height.
2. Position mower blades so blade ends point front to back.
3. On both sides of the unit, measure the distance to the ground at the front and rear tip of the blade. See Figure 44.

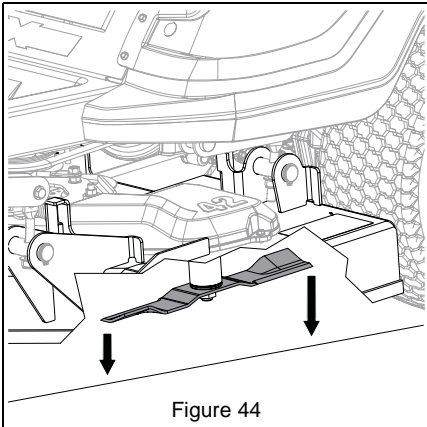

TROUBLESHOOTING

Problem	Probable Cause	Correction
Engine does not start.	Safety Interlock System is not engaged or is faulty.	Check Safety Interlock System. See <i>Check Safety Interlock System</i> on page 20.
	Fuel tank is empty.	Fill fuel tank. See <i>Before Operating Unit</i> on page 13.
	Fuel supply is contaminated.	Replace with clean fuel.
	Battery is discharged.	Charge battery. See <i>Charge Battery</i> on page 24.
	Connection between battery and battery cables is poor.	Tighten and/or clean battery and battery cables. See <i>Clean Battery</i> on page 24.
	Spark plug wire(s) are loose or spark plug(s) are faulty.	Connect spark plug wire(s) or replace spark plug(s). Refer to engine manual.
	Electrical system is faulty.	Contact your Gravelly dealer.
Engine runs rough.	Engine is faulty.	Contact your Gravelly dealer.
	Choke control knob is in on position. (Models 915204, 915206, 915218, 915230, 915236, 915238, 915240, 915242)	Move knob to off position.
	Air filter cartridge is plugged.	Clean or replace air filter cartridge. Refer to engine manual.
Engine overheats.	Engine is faulty.	Contact your Gravelly dealer.
	Engine oil level is low.	Add engine oil. Refer to engine manual.
	Cooling fins are plugged.	Clean engine. Refer to engine manual.
Unit does not drive.	Engine is faulty.	Contact your Gravelly dealer.
	The transaxles are bypassed.	Engage levers. See <i>Move Unit Manually</i> on page 15.
	Ground drive belt is faulty.	Contact your Gravelly dealer.
PTO malfunctions.	Transaxles are faulty.	Contact your Gravelly dealer.
	Operator presence switch is not engaged.	Activate switch by sitting on operator seat.
	Operator presence switch is faulty.	Contact your Gravelly dealer.
	Deck drive belt is faulty.	Replace deck drive belt. See <i>Remove Deck Drive Belt</i> on page 24.
Unit moves with engine off and parking brake engaged.	PTO switch, wiring, connectors or clutch are faulty.	Contact your Gravelly dealer.
	Parking brake needs adjustment.	Adjust parking brake lever. See <i>Adjust Parking Brake Lever</i> on page 30.
Unit does not track straight.	Parking brake is faulty.	Contact your Gravelly dealer.
	Tire pressure is incorrect.	Check tire pressure. See <i>Specifications</i> on page 37.
	Steering levers need adjustment.	See <i>Adjust Steering Levers</i> on page 28.
Unit creeps when steering levers are in neutral position.	Transaxles and/or linkages need adjustment.	Contact your Gravelly dealer.
	Transmission and/or linkage need adjustment.	Contact your Gravelly dealer.

TROUBLESHOOTING

Problem	Probable Cause	Correction
Poor cutting quality.	Mower blades not level or mower deck pitch is incorrect.	Level and adjust pitch of mower deck. See <i>Adjust Mower Deck</i> on page 32.
	Mower blades are dull or faulty.	Sharpen or replace mower blades. See <i>Sharpen Blades</i> on page 22.
	Mowing speed is too fast.	Drive slower when cutting grass.
	Belt tension or condition is poor.	Replace deck drive belt. See <i>Check Mower Belts</i> on page 24.
	Cutting height is too low.	Do not set height of cut too low. For very tall grass, mow twice.

STORAGE

SHORT-TERM STORAGE

IMPORTANT: NEVER wash unit with high-pressure water or store outdoors.

1. Allow unit to cool and clean with mild soap and water.
2. Tighten all hardware to correct specifications.
3. Inspect unit for visible signs of wear or damage. Repair as needed.
4. Prepare fuel system for storage.

NOTICE: Gravely recommends using a quality fuel stabilizer in all fuel. Gasoline left in the fuel system without a stabilizer, even for short periods of time, deteriorates and leaves gummy deposits in the system that may damage the carburetor and fuel hoses, filter and tank. For the best effectiveness, add stabilizer to all fuel containers whenever purchasing fuel. Add the stabilizer to the container before adding fuel.

- a. Add fuel stabilizer (see *Service Parts* on page 16) or equivalent according to manufacturer's instructions to the fuel tank and any fuel containers with remaining fuel.
 - b. Run engine outdoors for at least 5 minutes to allow stabilizer to reach the carburetor.
5. Turn ignition key to off position and remove from ignition.
 6. Store unit in a cool, dry, protected area. DO NOT store unit outdoors.

LONG-TERM STORAGE

1. Perform short-term storage procedures.
2. Lubricate as directed in *Maintenance* on page 16.
3. Touch-up all scratched painted surfaces.
4. Remove and charge battery as directed in *Charge Battery* on page 24. Store battery in a cool, dry, protected area.
5. Store unit in a cool, dry, protected area. Do not store unit outdoors.

START-OF-SEASON PREPARATION

1. Before adding fuel for the first time after long-term storage, add fresh, stabilizer-treated fuel to fuel tank and any fuel containers with remaining fuel.
2. Charge and install the battery.

ACCESSORIES

See your Gravely dealer for a complete list of compatible accessories and attachments for your unit.

Description	Part No.
Mulch Kit – 42"	71513900
Mulch Kit – 52"	71514000
Mulch Kit – 60"	71514400
Headlight Kit	71514100
Bagger Kit – 42" & 52"	81504300
Bagger Kit – 60"	81504300
Kit for 60" Decks	71514500

SPECIFICATIONS

Model Number	915172	915174	915176
Model	ZT X 42	ZT X 52	ZT X 42 CARB
Engine	Kohler 7000 Pro Twin with Smart Choke		
Engine Displacement – cm ³ (in ³)	725.0 (44.2)		
Maximum RPM – No Load	3300		
Oil Capacity	Refer to Engine Manual		
Drive			
Forward Maximum – km/h (mph)	11.3 (7.0)		
Reverse Maximum – km/h (mph)	4.8 (3.0)		
Turning Radius	Zero		
Brakes	Internal Transmission		
Electrical			
Starter	Electric		
Battery	12V Maintenance-Free 190CCA (U1 Replaceable)		
PTO (Power Take-Off)	Electric		
Fuel			
Fuel Tank Capacity – Liter (gal)	10.5 (2.8)		
Size and Weight			
Length – cm (in)	196.9 (77.5)		
Width – cm (in)	137.7 (54.2)	161.0 (63.4)	137.7 (54.2)
Weight – kg (lbs.)	258.5 (570.0)	279.0 (615.0)	258.5 (570.0)
Height – cm (in)	103.9 (40.9)		
Tires			
Front Tire Size – in	11 x 4-5		
Rear Tire Size – in	18 x 8.5-8		
Recommended Front Tire Pressure – kPa (psi)	317.2 (46.0)		
Recommended Rear Tire Pressure – kPa (psi)	68.5 (10.0)		
Mower Deck			
Cutting Height – cm (in)	3.8 – 11.4 (1.5 – 4.5)		
Cutting Width – cm (in)	106.7 (42.0)	132.1 (52.0)	106.7 (42.0)
Mower Deck Lift	Foot Operated		
Towing			
Max. Towing Capacity – kg (lbs)	136.0 (300.0)		
Max. Tongue Weight – kg (lbs)	13.6 (30.0)		
Transmission			
Type	Maintenance-Free Hydro-Gear® EZT Transaxles		

SPECIFICATIONS

Model Number	915200	915202	915204	915206
Model	ZT XL 52	ZT XL 42	ZT XL 52	ZT XL 42
Engine	Kohler 7000 Pro with Smart Choke		Kawasaki FR	
Engine Displacement – cm ³ (in ³)	725.0 (44.2)		726.0 (44.3)	
Maximum RPM – No Load	3300			
Oil Capacity	Refer to Engine Manual			
Drive				
Forward Maximum – km/h (mph)	11.3 (7.0)			
Reverse Maximum – km/h (mph)	4.8 (3.0)			
Turning Radius	Zero			
Brakes	Internal Transmission			
Electrical				
Starter	Electric			
Battery	12V Maintenance-Free 190CCA (U1 Replaceable)			
PTO (Power Take-Off)	Electric			
Fuel				
Fuel Tank Capacity – Liter (gal)	10.5 (2.8)			
Size and Weight				
Length – cm (in)	196.9 (77.5)			
Width – cm (in)	161.0 (63.4)	137.7 (54.2)	161.0 (63.4)	137.7 (54.2)
Weight – kg (lbs.)	308.0 (679.0)	299.8 (661.0)	308.9 (681.0)	300.7 (663.0)
Height – cm (in)	103.9 (40.9)			
Tires				
Front Tire Size – in	11 x 6-5			
Rear Tire Size – in	20 x 10-10	20 x 8-10	20 x 10-10	20 x 8-10
Recommended Front Tire Pressure – kPa (psi)	206.8 (30.0)			
Recommended Rear Tire Pressure – kPa (psi)	68.5 (10.0)			
Mower Deck				
Cutting Height – cm (in)	3.8 – 11.4 (1.5 – 4.5)			
Cutting Width – cm (in)	132.1 (52.0)	106.7 (42.0)	132.1 (52.0)	106.7 (42.0)
Mower Deck Lift	Foot Operated			
Towing				
Max. Towing Capacity – kg (lbs)	136.0 (300.0)			
Max. Tongue Weight – kg (lbs)	13.6 (30.0)			
Transmission				
Type	Hydro-Gear® ZT2800 with charge pumps and external filter			

SPECIFICATIONS

Model Number	915216	915218	915230
Model	ZT XL 60	ZT XL 60	ZT X 52
Engine	Kohler 7000 Pro with Smart Choke	Kawasaki FR730	Kawasaki FR691
Engine Displacement – cm ³ (in ³)	725.0 (44.2)	726.0 (44.3)	
Maximum RPM – No Load	3300		
Oil Capacity	Refer to Engine Manual		
Drive			
Forward Maximum – km/h (mph)	11.3 (7.0)		
Reverse Maximum – km/h (mph)	4.8 (3.0)		
Turning Radius	Zero		
Brakes	Internal Transmission		
Electrical			
Starter	Electric		
Battery	12V Maintenance-Free 190CCA (U1 Replaceable)		
PTO (Power Take-Off)	Electric		
Fuel			
Fuel Tank Capacity – Liter (gal)	10.5 (2.8)		
Size and Weight			
Length – cm (in)	196.9 (77.5)		
Width – cm (in)	181.6 (71.5)	161.0 (63.4)	
Weight – kg (lbs.)	314.8 (694)	316.2 (697)	274.4 (605.0)
Height – cm (in)	103.9 (40.9)		
Tires			
Front Tire Size – in	11 x 6-5	11 x 4-5	
Rear Tire Size – in	20 x 12-10	18 x 8.5-8	
Recommended Front Tire Pressure – kPa (psi)	206.8 (30.0)	317.2 (46.0)	
Recommended Rear Tire Pressure – kPa (psi)	68.5 (10.0)		
Mower Deck			
Cutting Height – cm (in)	3.8 – 11.4 (1.5 – 4.5)		
Cutting Width – cm (in)	152.4 (60.0)	132.1 (52.0)	
Mower Deck Lift	Foot Operated		
Towing			
Max. Towing Capacity – kg (lbs)	136.0 (300.0)		
Max. Tongue Weight – kg (lbs)	13.6 (30.0)		
Transmission			
Type	Hydro-Gear® ZT2800 with charge pumps and external filter	Maintenance-Free Hydro-Gear® EZT Transaxles	

SPECIFICATIONS

Model Number	915236	915238	915240	915242
Model	ZT-X 52 CARB	ZT-XL 42 CARB	ZT-XL 52 CARB	ZT-XL 60 CARB
Engine	Kawasaki FR691V CARB	Kawasaki FR651V CARB	Kawasaki FR691V CARB	Kawasaki FR730V CARB
Engine Displacement – cm ³ (in ³)	726.0 (44.3)			
Maximum RPM – No Load	3300			3300 ± 100
Oil Capacity	Refer to Engine Manual			
Drive				
Forward Maximum – km/h (mph)	11.3 (7.0)			
Reverse Maximum – km/h (mph)	4.8 (3.0)			
Turning Radius	Zero			
Brakes	Internal Transmission			
Electrical				
Starter	Electric			
Battery	12V Maintenance-Free 190CCA (U1 Replaceable)			
PTO (Power Take-Off)	Electric			
Fuel				
Fuel Tank Capacity – Liter (gal)	10.5 (2.8)			
Size and Weight				
Length – cm (in)	196.9 (77.5)			
Width – cm (in)	161.0 (63.4)	137.7 (54.2)	161.0 (63.4)	181.6 (71.5)
Weight – kg (lbs.)	279.0 (615.0)	299.8 (661.0)	308.9 (681.0)	314.8 (694)
Height – cm (in)	103.9 (40.9)			
Tires				
Front Tire Size – in	11 x 4-5	11 x 6-5		
Rear Tire Size – in	18 x 8.5-8	20 x 8-10	20 x 10-10	20 x 12-10
Recommended Front Tire Pressure – kPa (psi)	317.2 (46.0)	206.8 (30.0)		
Recommended Rear Tire Pressure – kPa (psi)	68.5 (10.0)			
Mower Deck				
Cutting Height – cm (in)	3.8 – 11.4 (1.5 – 4.5)			
Cutting Width – cm (in)	132.1 (52.0)	106.7 (42.0)	132.1 (52.0)	152.4 (60.0)
Mower Deck Lift	Foot Operated			
Towing				
Max. Towing Capacity – kg (lbs)	136.0 (300.0)			
Max. Tongue Weight – kg (lbs)	13.6 (30.0)			
Transmission				
Type	Maintenance -Free Hydro- Gear® EZT Transaxles	Hydro-Gear® ZT2800 with charge pumps and external filter		



Consumer Mowing Equipment Limited Warranty

Ariens Company (Ariens) warrants to the **original purchaser** that Ariens, Gravely and Countax brand lawn and garden consumer products purchased on or after 9/1/2016 will be free from defects in material and workmanship for the time period noted in the chart below. Equipment put to personal use around a single household or residence is considered "Consumer Use"; equipment put to any business use (agricultural, commercial, or industrial) or used at multiple locations is considered "Commercial Use." If any product is rented or leased, then the duration of these warranties shall be 90 days after the date of purchase.

An authorized Ariens dealer (Ariens brand products), Gravely dealer (Gravely brand products), or Countax dealer (Countax brand products) will repair any defect in material or workmanship, and repair or replace any defective part, subject to the conditions, limitations and exclusions set forth herein. Such repair or replacement will be free of charge (labor and parts) to the original purchaser except as noted below.

Warranty Code	Product Group	Warranty Period Consumer Use	Warranty Period Commercial Use
HA	Zoom, ZT, IKON-X, IKON-XL, ZT-X, ZT-XL Zero-Turn Riders	3 Years	90 Days
HB	Apex, Max Zoom & ZT HD Zero-Turn Riders	3 Years	1 Year
HC	"936" Tractors, "961" Series Walk-Behind Mowers	2 Years	90 Days
HD	Classic LM Series Mowers; Wide Area Walk Mowers; Razor, XD3	3 Years	90 Days
N/A	Service (replacement) Parts	90 Days (no labor)	90 Days (no labor)
AA	Serialized Attachments	1 Year	1 Year

Special Extensions

The chart below details special extensions to this warranty:

Warranty Code	Warranty Exception	Warranty Period	Use	Detail
HA, HB	Mower Deck Shell on Zero-Turn Riders	5 Years	Consumer	3 years parts and labor Additional 2 years parts only
HA, HB	Main Frame on Zero-Turn Riders	5 Years	Consumer	3 years parts and labor Additional 2 years parts only

Exceptions and Limitations

The chart below details special exceptions to this warranty:

Warranty Code	Warranty Exception	Warranty Period	Use	Detail
All	Batteries	1 Year	Consumer	Prorated
All	Belts, Muffler, Tires	None	Commercial	These components are not covered when used commercially.
All	Cloth, Plastic, and Rubber Components (Including Belts and Cables)	Maximum 2 Years	All	Warranty is limited to 2 years for consumer use. Except as noted above, these components are covered for defect, not for wear.
All	Engines	See Engine Manufacturer's Warranty	All	Engines are covered by engine manufacturer's warranty. Refer to engine manufacturer's warranty statement.

Customer Responsibilities

Register the product immediately at the time of sale. If the dealer does not register the product, the customer must complete the product registration card in the literature package and return it to the Ariens Company, or register the unit online at www.ariens.com, www.gravely.com, www.countax.com.

To obtain warranty service, the **original purchaser** must:

- Perform the maintenance and adjustments explained in the owner's manual.

- Promptly notify Ariens or an authorized Ariens, Gravely or Countax service representative of the need for warranty service.
- Transport the product to and from the place of warranty service at owner's expense.
- Have the warranty service performed by an authorized Ariens, Gravely or Countax service representative.

To Find an Authorized Service Representative:

In the U.S. and Canada:		
Use the dealer locator on our websites: www.ariens.com • www.gravely.com		
Or contact us by mail or by phone:		
In the U.S., Canada, Mexico, Caribbean, Central and South America:	In Europe, Asia, Africa or the Middle East:	In Australia or New Zealand:
Ariens Company 655 W. Ryan Street Brillion, WI 54110 Phone: (920) 756 - 4688 www.ariens.com	Ariens Company Limited Great Haseley, Oxford OX44 7PF United Kingdom Phone: +44 800 597 7777 www.countax.co.uk	Allpower Industries Pty Ltd 128 Bridge Rd Keysborough VIC 3173 Australia Phone: +61 1800 333 428 www.allpower.com.au

Exclusions – Items Not Covered by This Warranty

- Parts that are not genuine Ariens, Gravely or Countax service parts are not covered by this warranty and may void the warranty.
- Damages resulting from the installation or use of any part, accessory, or attachment which is not approved by the Ariens Company for use with product(s) identified herein are not covered by this warranty.
- The following maintenance, service and replacement items are not covered by this warranty unless they are noted in the Limitations section above: lubricants, spark plugs, oil, oil filters, air filters, fuel filters, brake linings, brake arms, brake shoes, skid shoes, scraper blades, shear bolts, mower blades, mower vanes, brushes, headlights, light bulbs, knives, cutters.
- Any misuse, alteration, improper assembly, improper adjustment, neglect, or accident which requires repair is not covered by this warranty.
- **Use of gasoline blends exceeding 10% ethanol voids any and all warranties.**
- Products are designed to the specifications in the area that the product was originally distributed. Different areas may have significantly different legal and design requirements. This warranty is limited to the requirements in the area in which the unit was originally distributed. Ariens Company does not warrant this product to the requirements of any other area. Warranty service is limited to service within the area originally distributed.
- In countries other than the United States and Canada, contact the Ariens Company dealer for warranty policies that govern within your country. Rights may vary from country to country and within any one country.

Disclaimer

Ariens Company may from time to time change the design of its products. Nothing contained in this warranty shall be construed as obligating the Ariens Company to incorporate such design changes into previously manufactured products, nor shall such changes be construed as an admission that previous designs were defective.

LIMITATION OF REMEDY AND DAMAGES

Ariens Company's liability under this warranty, and under any implied warranty that may exist, is limited to repair of any defect in workmanship, and repair or replacement of any defective part. Ariens Company shall not be liable for incidental, special, or consequential damages (including lost profits). Some states do not allow the exclusion of incidental or consequential damages, so the above limitation or exclusion may not apply to you.

AUSTRALIAN CONSUMER LAW

The following applies solely to warranties subject to Subsection 102(1) of the Australian Consumer Law: Our goods come with guarantees that cannot be excluded by the Australian Consumer Law. You are entitled to a replacement or refund for a major failure and for compensation for any other reasonably foreseeable loss or damage. You are also entitled to have the goods repaired or replaced if the goods fail to be of acceptable quality and failure does not amount to a major failure.

DISCLAIMER OF FURTHER WARRANTY

Ariens Company makes no warranty, express or implied, other than what is expressly made in this warranty. If the law of your state provides that an implied warranty of merchantability, or an implied warranty of fitness for particular purpose, or any other implied warranty, applies to Ariens Company, then any such implied warranty is limited to the duration of this warranty. Some states do not allow limitations on how long an implied warranty lasts, so the above limitation may not apply to you.

This warranty gives you specific legal rights, and you may also have other rights which vary from region to region.



GRAVELY.

655 West Ryan Street
Brillion, WI 54110

gravelymower.com
gravely.custhelp.com

WARNING

The engine exhaust from this product contains chemicals known to the State of California to cause cancer, birth defects and other reproductive harm.

An *Ariens* Company Brand

